

# Manual

---

Compact cash drawer  
in white

**securePRO-303WN**

## Table of contents

Specifications:.....	2
Kit contents:.....	2
Product Description.....	3
Opening and closing the cash drawer .....	4
Removing the money tray .....	5
Connecting the drawer .....	6
Maintenance.....	6

## Specifications:

- **Warranty:** 1 year
- **Colour:** white with black surround on the front
- **Outer Material:** Aluminum Alloy
- **Surface Finish:** Anodized
- **Sliding system:** bearing guide
- **Number of compartments:** 5 compartments for banknotes, 8 compartments for coins
- **Lock:** three-position with four functions (drawer open/close, manual opening, electronic opening)
- **Additional functions:** removable coin compartment, slot for other means of payment
- **Interface:** RJ12
- **External dimensions:** 30.35 W x 35 L x 10.2 H
- **Product Weight:** 6.6kg

## Kit contents:

- Cash drawer
- RJ12 cable
- 2 lock keys
- Manual

# Product Description

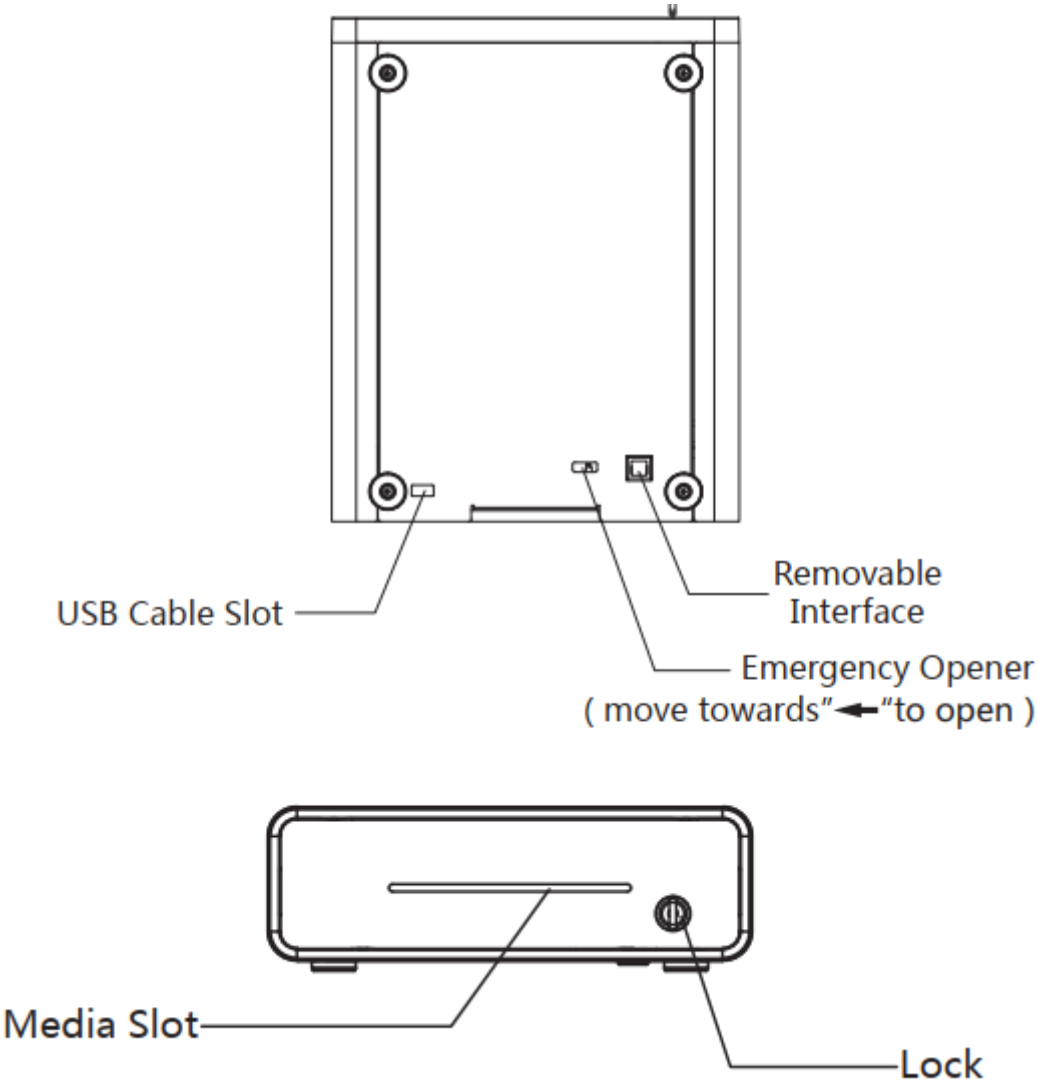

## Opening and closing the cash drawer

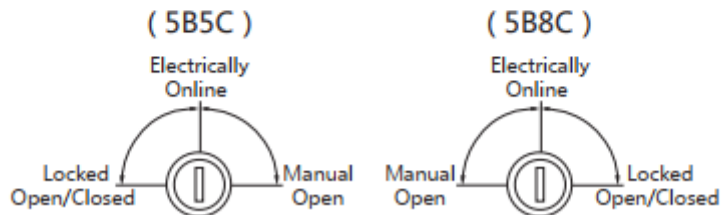
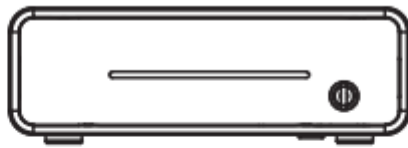

The lock has 4 functions:

- **manual opening**, which means that

Turning the key to this position will open the drawer.

- **electronic opening**, which means that the drawer can be opened from the cash register, after prior connection
- **locked opening**, which means the drawer cannot be opened without a key
- **Locked lock**, which means the drawers close without a key.

# Removing the money tray

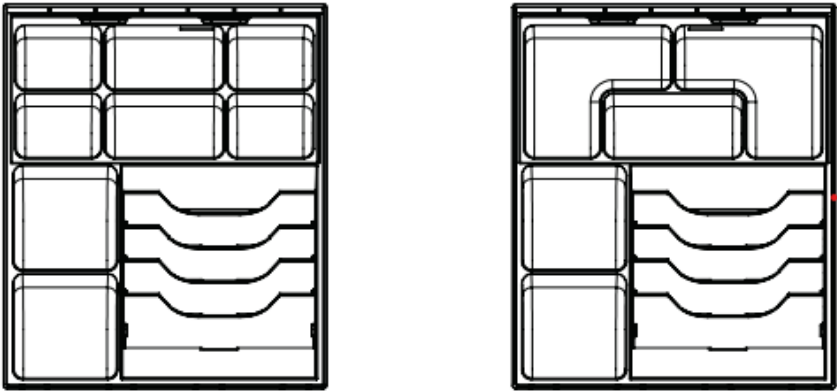
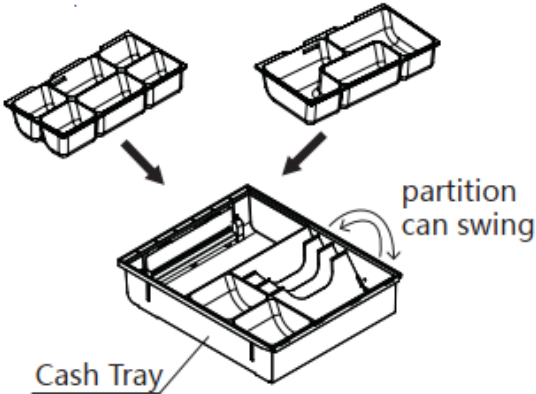
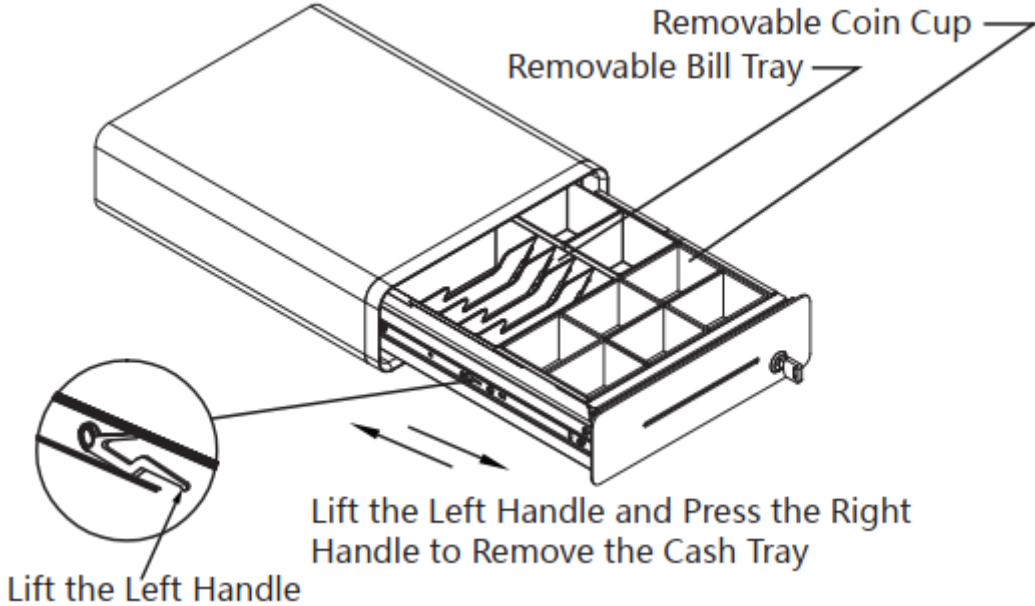

## Connecting the drawer

The cash drawer is equipped with a standard 6-pin RJ12 plug for direct connection to any EPSON POS printer or Epson-compliant POS equipment.

### Connection:

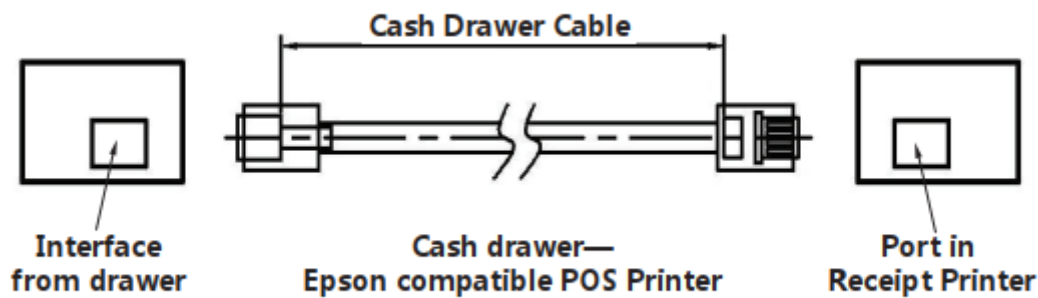

## Maintenance

The cash drawer sliders should be cleaned and lubricated periodically.

The frequency depends on the intensity of use and environmental conditions, but it is usually recommended to do this every three months. Using dry, lint-free

cloths should wipe off old greases and debris from the inner and outer zippers.

Do not use water or any liquid cleaners. Using a clean applicator, apply a thin layer of lithium bearing grease to the inner and outer guides. Then move the guides several times to properly coat the polyurethane rollers and distribute the lubricant evenly.