

Manual

Mount for 6 monitors
from 17 - 32 inches

SolidHand-CM06

Table of contents

Specifications: 3
Set contents:..... 4
Assembly:..... 4
Safety:..... 9

Specifications:

- **Warranty:** 1 year
- **Color:** Silver
- **Material:** Aluminum, Steel, Plastic
- **Surface Finish:** Powder Coating
- **Number of monitors:** 6
- **Min. monitor diagonal:** 17"
- **Max. monitor diagonal:** 32"
- **VESA Standard:** 75x75, 100x100
- **Weight per monitor:** 8 kg
- **Height adjustment:** manual
- **Arm swivel range:** +17° ~ -17°
- **Monitor swivel range:** +180° ~ -180°
- **Monitor tilt range:** +34° ~ -34°
- **Max. arm overhang:** 857 mm
- **Installation:** clamp, grommet, grommet
- **Handle dimensions:** 178.4 x 50.3 x 57.8 cm
- **Package dimensions:** 103(L) x 42(W) x 12(H) cm
- **Handle weight:** 15.5 kg
- **Handle weight with packaging:** 16.5 kg

Set contents:

- Monitor mount,
- screws and mounting washers,
- Installation instructions

Assembly:

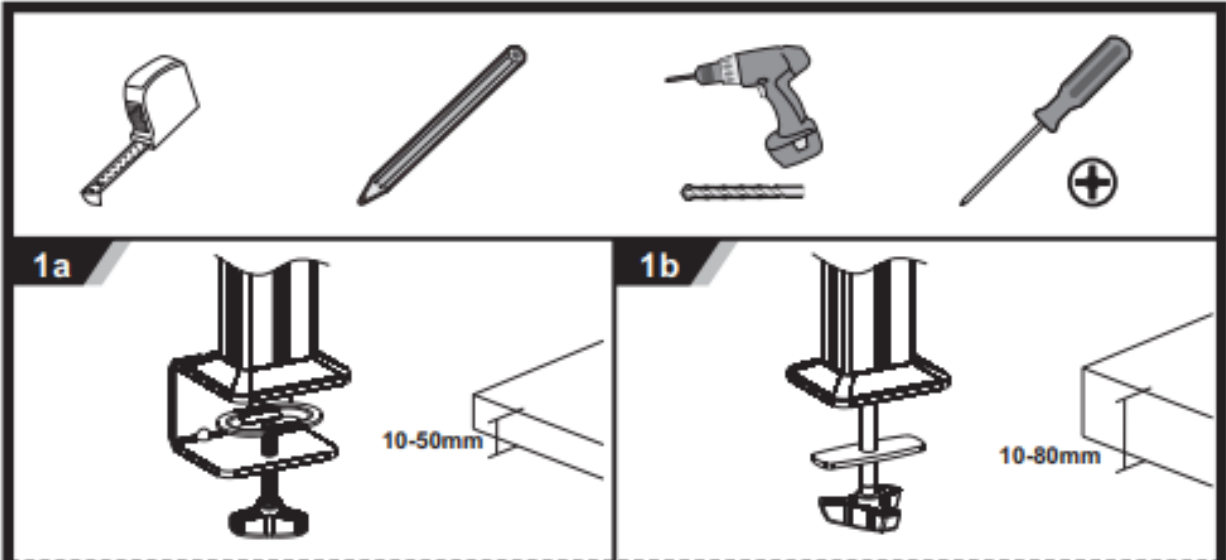
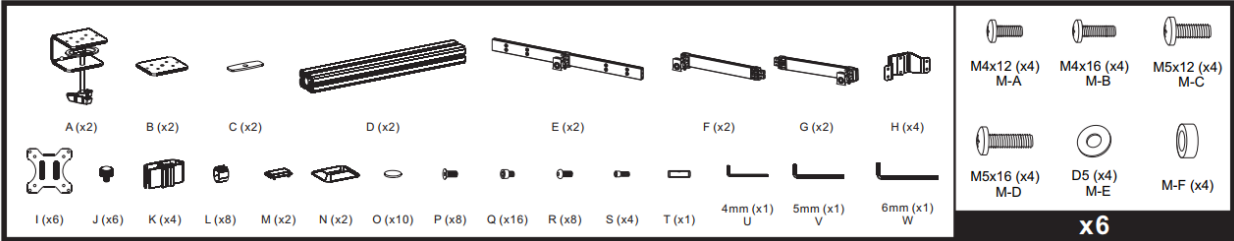

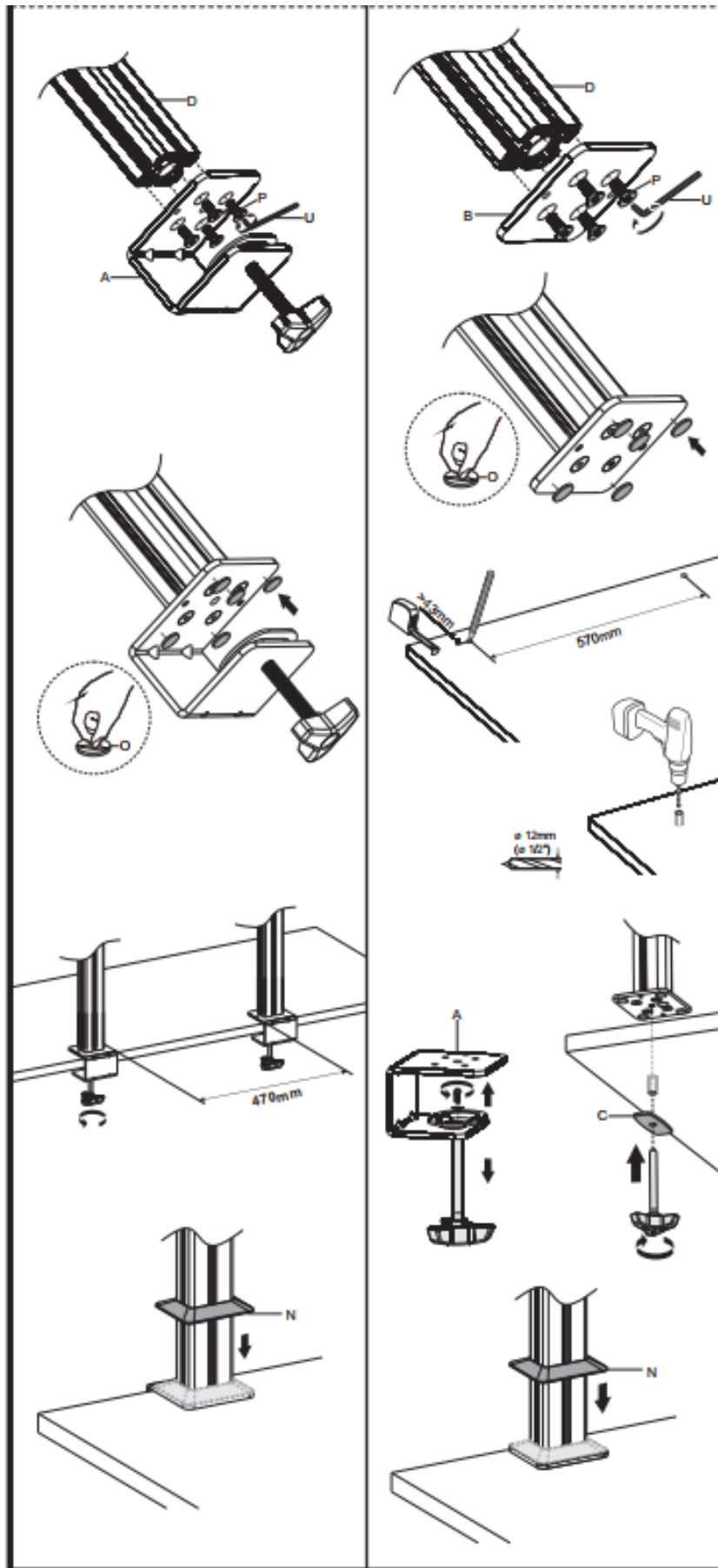

2

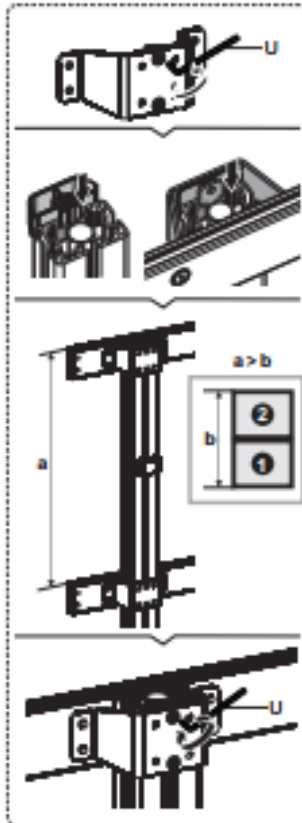
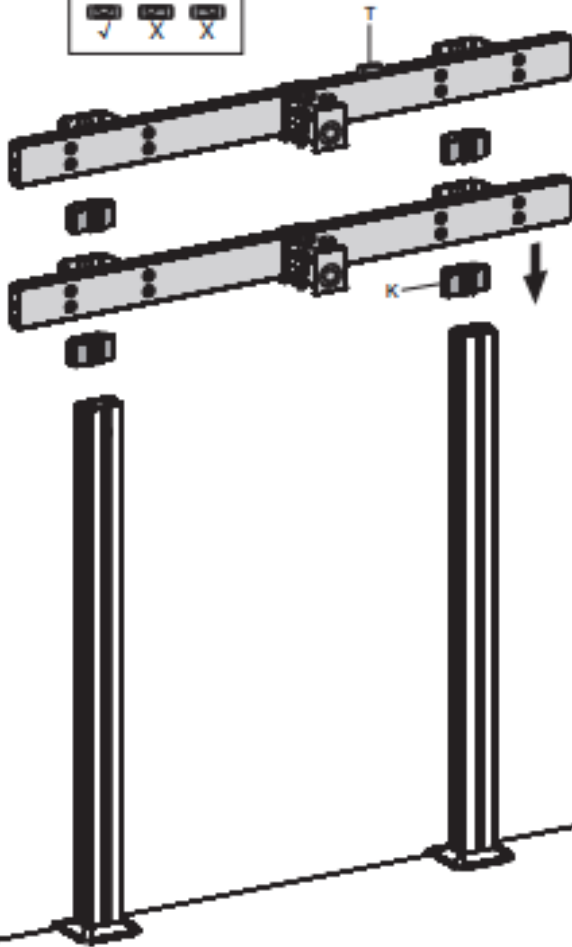
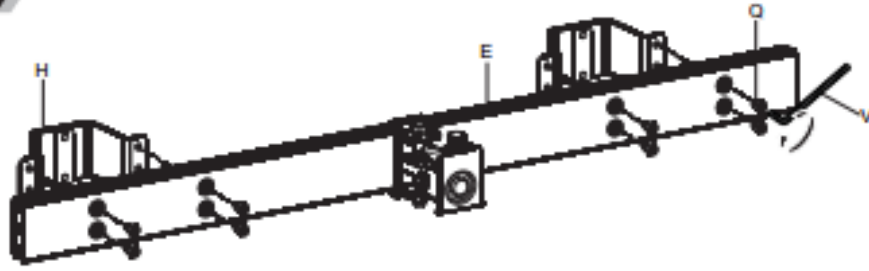

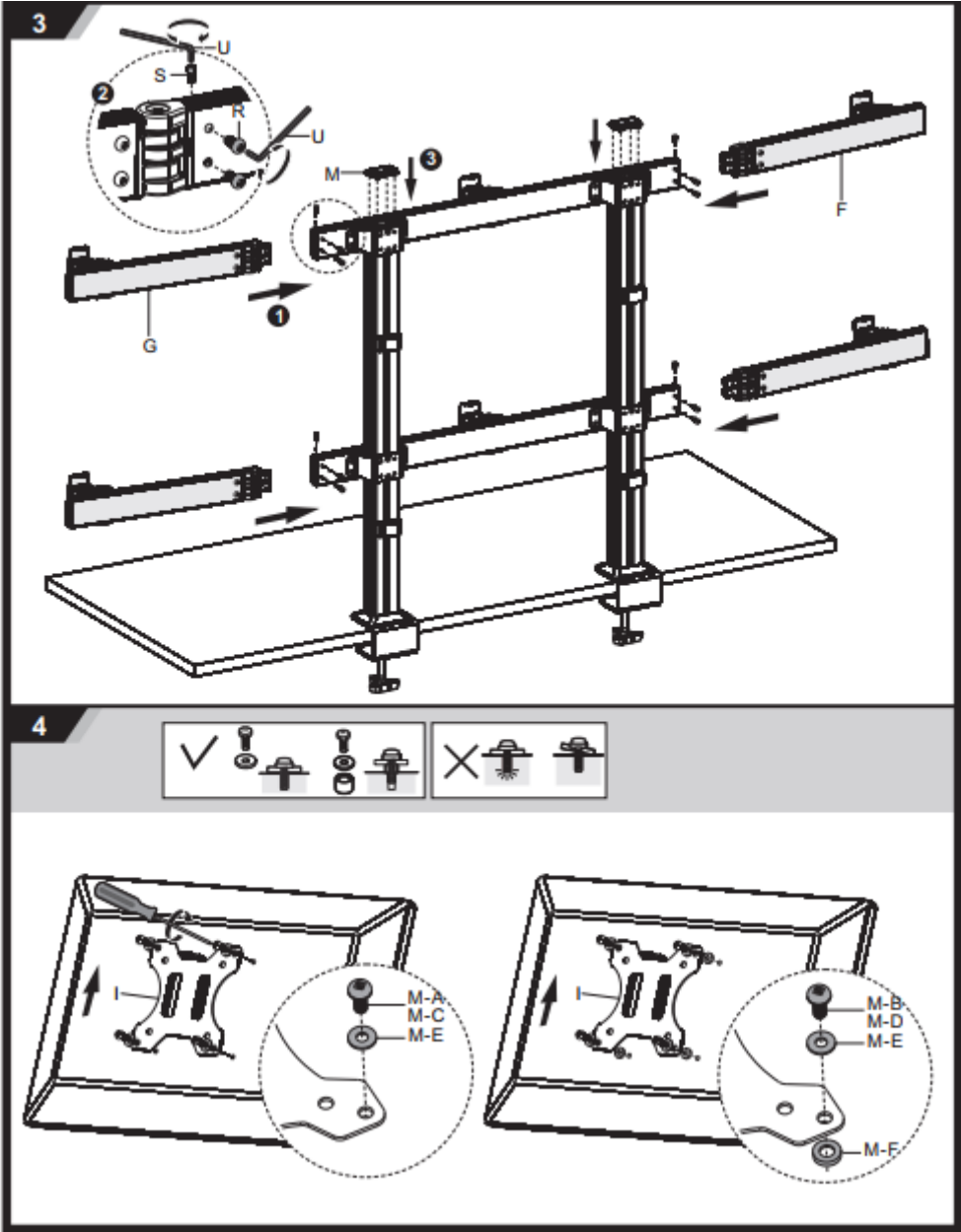

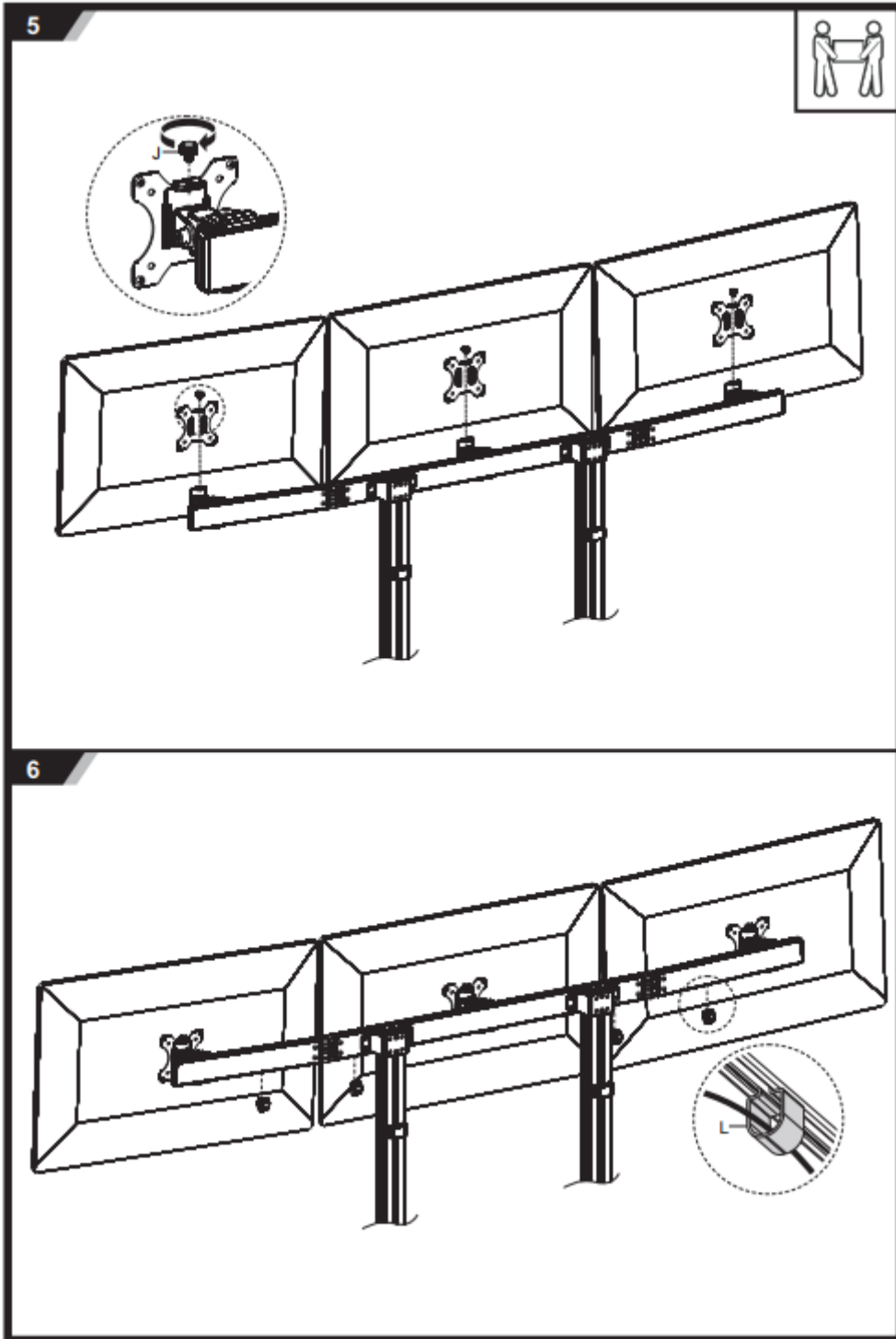

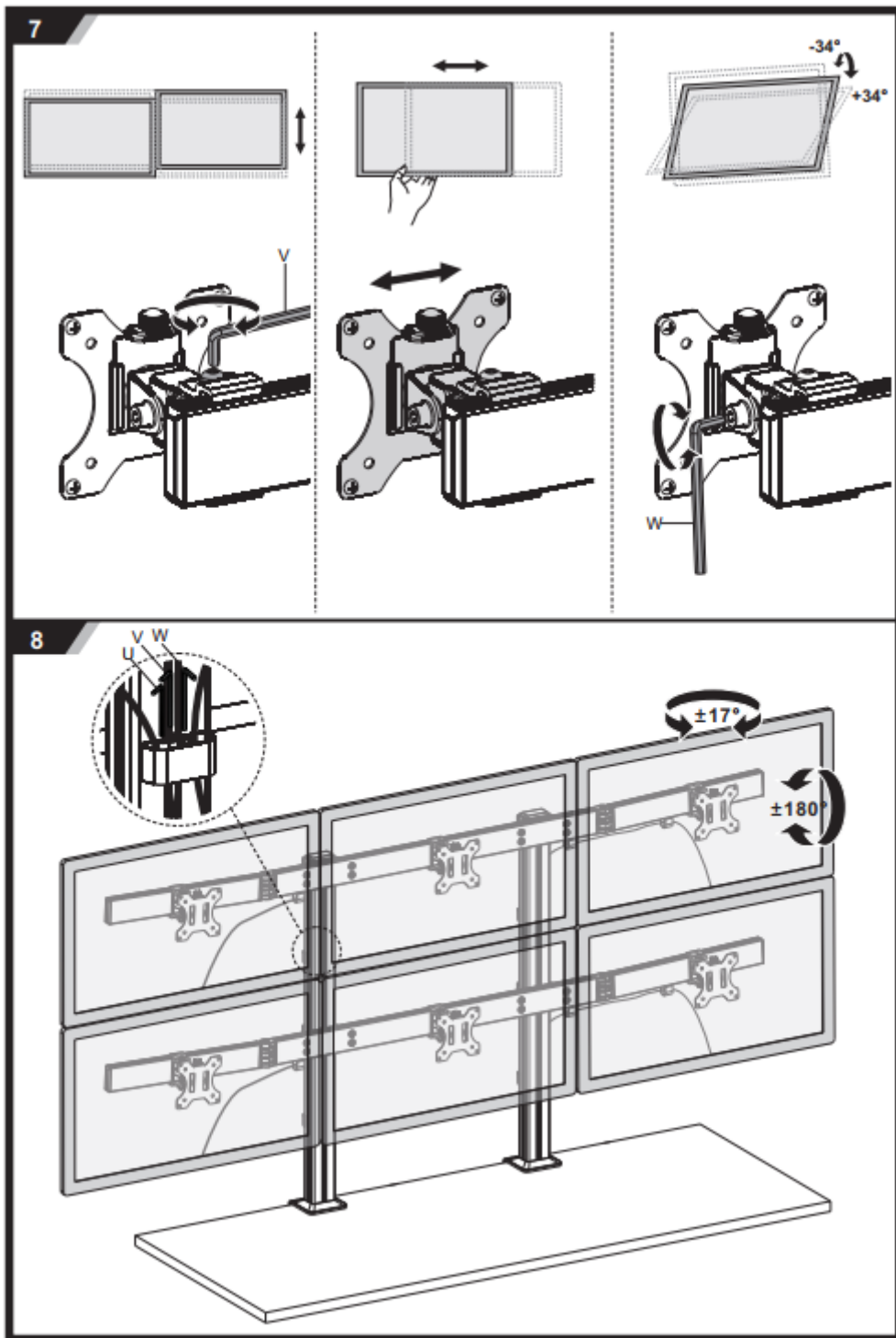

Safety:

CAUTION: Using the product with heavier weights than indicated may cause instability and possible injury.

- Please follow the assembly instructions carefully. Incorrect installation can lead to damage or serious injury.

- Use appropriate protective equipment and tools. The product should only be installed by professionals.
- Ensure that the mounting surface can securely support the combined weight of the device and all attached items and components.
- Use the mounting screws provided and **DO NOT OVERTIGHTEN the** mounting screws.
- The product contains small parts that may pose a choking hazard if swallowed. Keep these items away from children.
- The product is intended for indoor use. Using it outdoors may lead to damage to the product and personal injury.

IMPORTANT: Make sure you receive all parts according to the component checklist before installation. If any parts are missing or defective, please contact your dealer for replacement.

MAINTENANCE: Check that the product is safe and stable during use at regular intervals (at least once every three months).