

# User Manual

---

Smart door lock with  
access control

**SecureEntry-HL300**

## Table of contents

Specifications: .....	3
Set contents:.....	4
Features: .....	4
Safety and precautions.....	5
Utility Features .....	6
Kit contents.....	7
Schematic diagram of the installation of an electronic handle.....	8
Step-by-step smart lock installation.....	8
Door opening direction: Right .....	11
Door opening direction: left .....	12
Features and Operation.....	12
Manage access control functions.....	13
Other comments .....	15

## Specifications:

- **Warranty:** 1 year
- **Device Type:** RFID Electronic Handle with Access Control
- **Types of verification:** password, TUYA app, RFID card, fingerprint, mechanical key
- **User capacity in the database:** 300 (fingerprints, password, cards)
- **Number of administrators in the database:** 9
- **Material:** aluminum alloy
- **Groove:** 60 x 68
- **Fingerprint sensor:** Solid-state FPC
- **Compatible APP:** Tuya SMART or TTLock
- **Suitable Door Type:** Stainless Steel Door, Security Door, Copper Door, Wooden Door
- **Suitable Door Thickness:** 35-120mm
- **Additional functions:** tamper alarm, touch keypad, cooperation with the TUYA app, low power level alarm
- **Voltage:** 12V (8pcs AA 1.5V alkaline batteries, you can use an external USB emergency power supply)
- **Quiescent Current:** < 50-56 $\mu$ A
- **Operating Current:** > 250 $\mu$ A
- **Password length:** 6-8 digits
- **Operating temperature:** -10°C ~ 60°C
- **Operating Humidity:** 20%~93%
- **Zipper dimensions:** 36.8 x 7.5 x 2.4 cm

## Set contents:

- Front lock with handle
- Lock back plate with handle
- Connecting post
- Lock body
- Lock Core
- Plastic Insert
- 2x mechanical wrench
- Mounting screws
- 2 pcs. RFID cards
- Manual

## Features:

- Sleek, modern design
- Possibility to access rooms by fingerprint, RFID card, password and classically by means of a mechanical key
- Cooperation with Tuya SMART and TTLock applications allowing for remote operation of the electronic handle
- Can be installed in almost any type of door

## Safety and precautions

- A smart door lock is a high-tech product. Its installation, depending on whether it was done correctly or incorrectly, directly affects the normal operation and service life of the door lock. It is recommended to install through a qualified one.
- Do not use in environments with strong radiation, high magnetic field and high temperature corrosive substances, exposure to the above environmental factors may affect the performance and service life of the smart lock.
- After the door lock installation is complete, it must be initialized and returned to its initial state. Immediately after initialization, you should configure the electronic key settings to prevent others from opening the door lock illegally.
- It is recommended to use or replace an 8x AAA 1.5V alkaline battery of the same brand. Do not mix old batteries with new ones when replacing. Replace all batteries with new ones at once to avoid damage to the lock.
- Please read this manual carefully before using the appliance and if you have any doubts, please contact our company customer service centre directly.

**Remark! Batteries are not included.**

## Utility Features

The device offers verification by fingerprint, RFID card, password, mechanical key and WeChat dynamic code, and security combination verification mode randomly for fingerprint + password + RFID card. Once successfully verified by the user, the door will be unlocked. The door will lock again after 5 seconds (the locking time can also be set to 3 seconds).







**The following authentication mode is supported to unlock the door:**

- Fingerprint
  - RFID Card
  - Mini program WeChat
  - Application
  - Password
  - Mechanical wrench
1. The door can be unlocked via fingerprint, RFID card, one-way unlock password or any combination of the three security verification modes, and optionally via an app. If electronic verification does not work, use the unlock key included in the kit.
  2. The electronic handle offers a large memory capacity: 1000 fingerprints (5 as administrator, 99 as user). 10 passwords (2 as administrator, 8 as user), 99 RFID cards.
  3. This product uses a standard straight up-down lock body.
  4. Depending on the installation of the handle, the door can open both to the left and to the right.

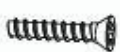
## Comments

1. The electronic handle only supports cards with Mifare 1 chip, it does not recognize other types of cards.
2. The lock does not support dual ID card mode.

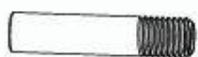
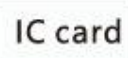
## Kit contents

Item No.	Picture	Accessories	Quantity	Remark
1		Cross round-head screw	1pc	4.89×35mm
2		Cross round-head screw	2pc	4.89×50mm
3		plug	1pc	
4		Square rod	1pc	7.9×80mm
5		Lock knob iron sheet	1pc	90×8.2mm
6		Installation stud	2pc	7.7×34.5mm
7		IC card	2pc	If lost, please cancel on the smart lock
8		Key	2pc	please store separately, do not put in the indoor

## Schematic diagram of the installation of an electronic handle

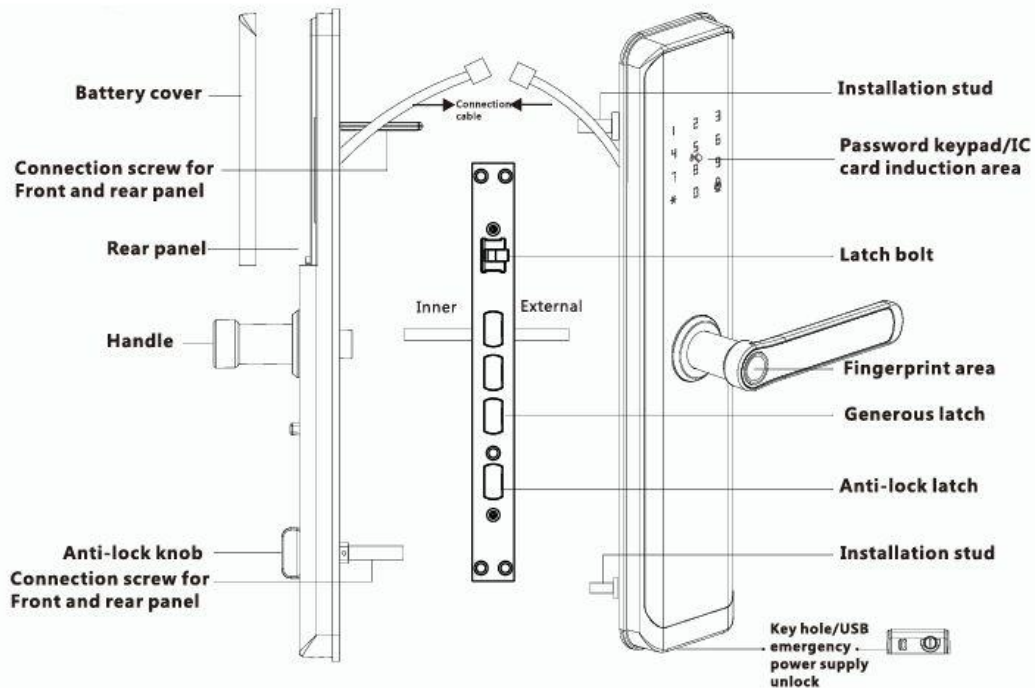

### Step-by-step smart lock installation

Stand away from the door to determine the direction of door opening and adjust the direction of the handle and mortise latch.

**Note:** Before installation, please make sure whether the arrow direction of the rotating rod on the front panel is parallel to the line of the handle, if not, do not insert the key into the lock and do not turn it.

1. Use a screwdriver to loosen the screw in the handle hole at the bottom of the lock face.

2. Install the handle loosely, adjust the direction within 180 degrees, and then tighten the handle screw.
3. The direction of the rotary rod arrow at the bottom of the lock must be in the direction of the handle.

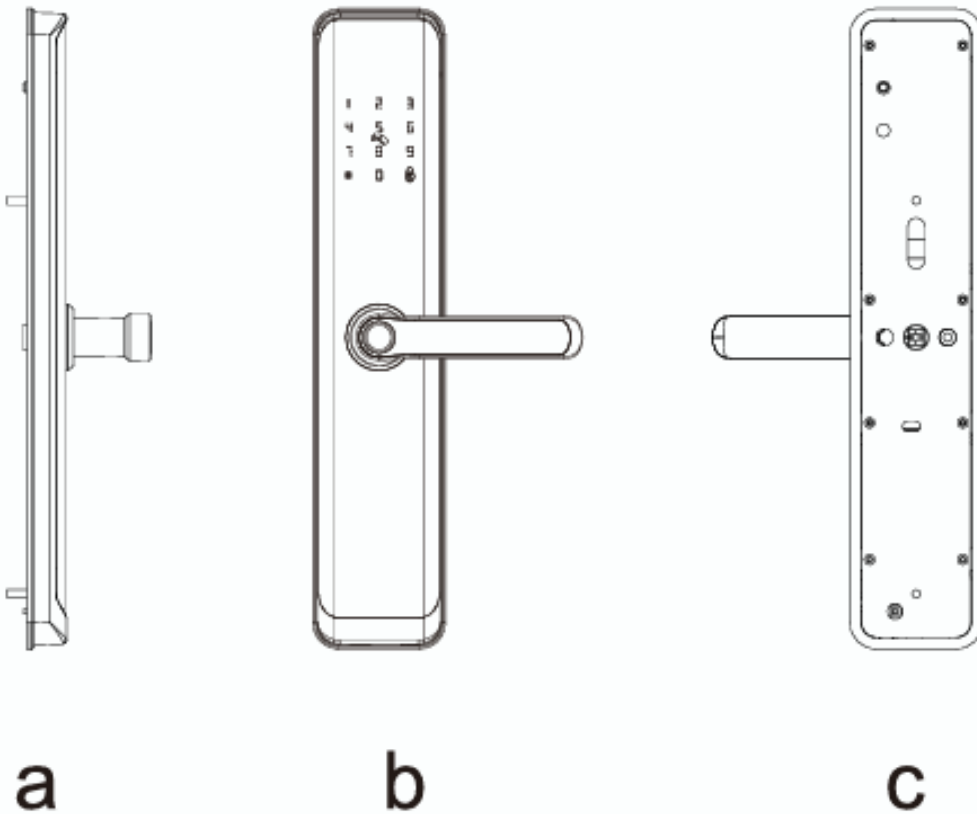

4. After carefully adjusting the direction of the keyway, install the keyway and fasten the 4 screws to the board. Then install the front and rear panels and mounting screws.
5. Install the door buckle plate, adjust the relative position of the lock latch and door buckle plate to ensure smooth opening when locked.
6. Once installed, try unlocking and locking the door, then check and tighten all screws.

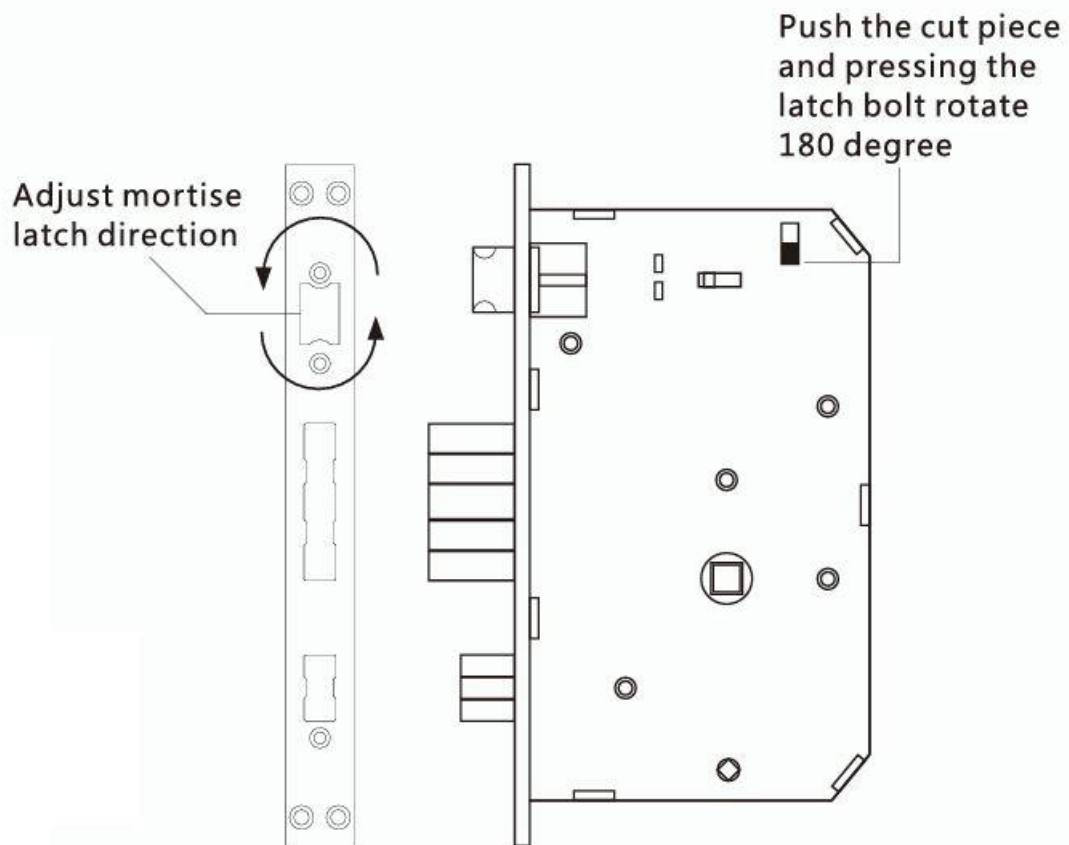

## Remark

**Be careful with the direction of the latch screw.**

Once you have determined the direction of the door opening, if you need to adjust the direction of the mortise latch bolt, push the cut piece and press the latch bolt by turning it 180 degrees.

Door opening direction: Right

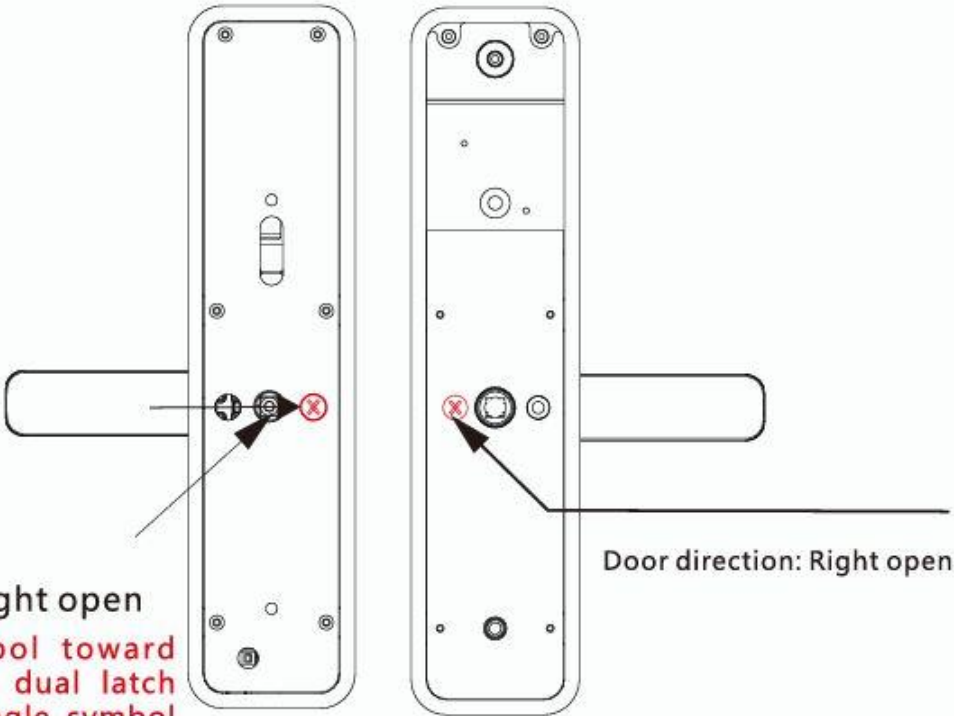

Door direction: Right open  
The triangle symbol toward downward if using dual latch lock body, the triangle symbol corresponds to Handle direction if using single latch lock body.

**Front panel**

**Back panel**

Door opening direction: left

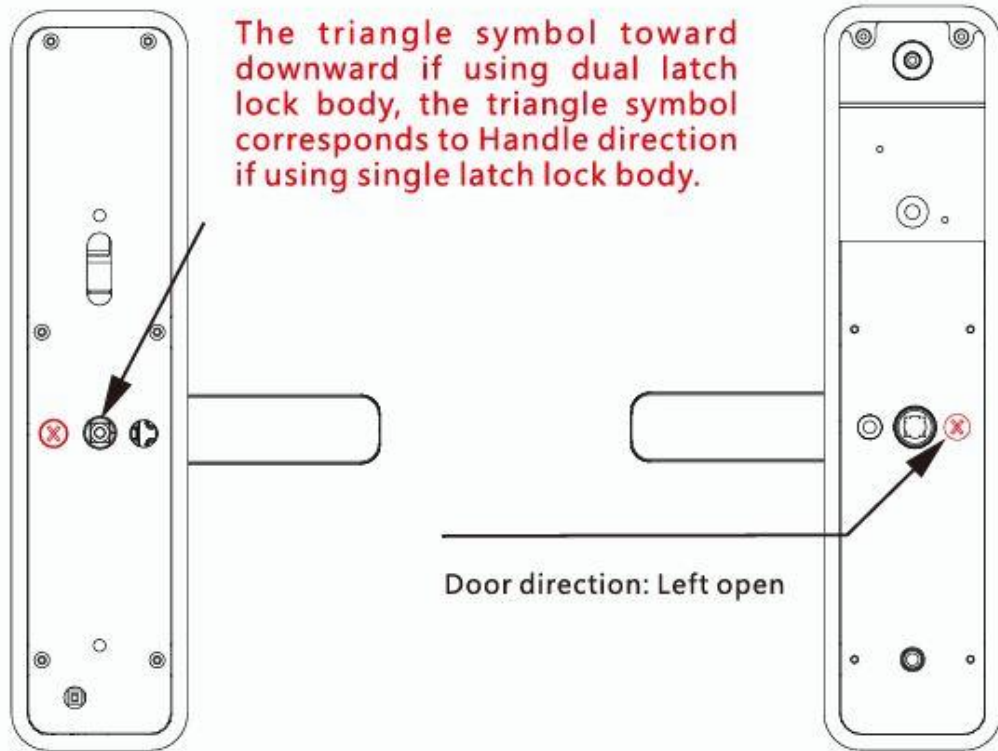

**Front panel**

**Back panel**

## Features and Operation

1. Unlock Information: refers to the fingerprint, password, or RFID card information entered (including administrators and regular users).
2. \* Key : Erase Key/Return Key
3. # key: confirmation key or menu function key

## Initial state

The factory administrator password is **123456**. In the initial state, any fingerprint, RFID card, or password can open the lock.

## Manage access control functions

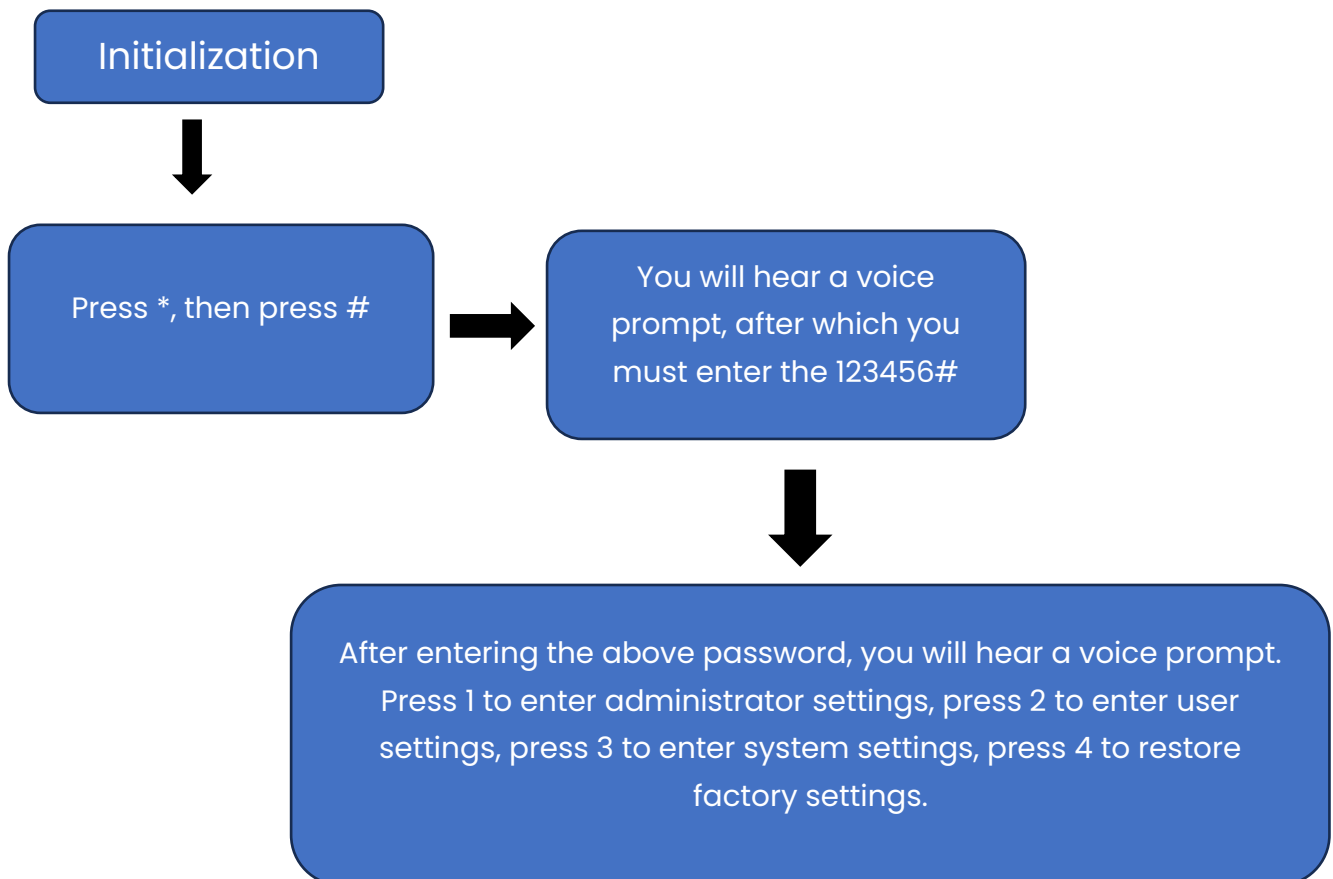

## Administrator settings

- To add an administrator, press 1, enter the administrator information, enter the fingerprint or password (enter the fingerprint 4 times, the 6-8 digit password twice (e.g., 888888#), and the RFID card once).
- To delete administrator information, press 2. Then enter the admin number and press # to confirm (e.g. 002#) (you can't delete all admins, one always remains).

- Adding networks. To initiate a hotspot connection, press 1. To invoke a smart call, press 2 (TUYA app).

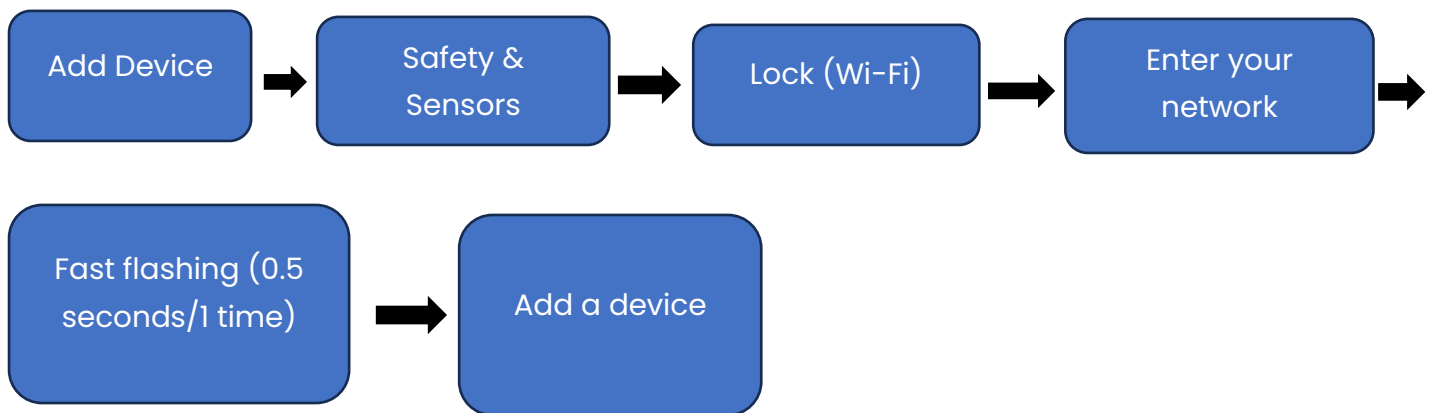

**Remote Unlock:** Wake up the screen and press 9 followed by #. A voice prompt will sound to let you know that a remote unlock request has been sent.

**Hotspot connection mode, smart connection mode:** After the network is successfully added on the keypad, \*5, 1, 2 will light up in succession and a voice prompt will be given.

When the network is not added, on the keyboard, \* 5, 1, 2 will not be illuminated, and a voice prompt will inform you of the failure.

### User settings

- **Adding a user:** Press 1. A voice prompt will inform you to enter your user information. Enter your fingerprint or password (enter your fingerprint 4 times, your 6-8 digit password twice, and your RFID card once). Once successful, you can enter the information of the next user.
- **Delete user:** Press 2 to select the option to delete the user. A voice prompt will tell you to press 1 and enter the number to delete (e.g., 010#). Pressing 2 will delete all users.
- **System Settings:** Press 3 to enter the system settings menu. A voice prompt will inform you that you can choose from

the different options. Press 1 to enter the sound setting, press 2 to set the unlock mode, press 3 to enter the language setting, press 4 to set the time, press 5 to change the room number.

- **Time Setting:** Press 4 to enter the time configuration. A voice prompt will let you know that the current time is **1903041153**. Modify the time based on the format (year-month-day-hour-minutes, for example: 1903031153), and then press # to confirm. A voice prompt will inform you of a successful action.
- **Modify the room number:** Press 5 to set your own room number. A voice prompt will inform you that the default room number is 8888. You can enter 4 digits and press # to confirm. A voice prompt will inform you of a successful operation.
- **Factory Reset:** Press the factory reset key located under the battery cover on the rear panel of the lock for about 6-8 seconds. You will hear a beep to indicate that the factory reset has been successful.

## Other comments

1. The system will automatically enter the lock state, after incorrect verification more than 5 times within 5 minutes. The blocked state will last for 90 seconds.
2. When the voltage drops below 4.5V, the lock will automatically alarm each time it is opened. Once the alarm is triggered, the lock can be opened 200 times. Once this number is exceeded, each unlock delay is 5 seconds.

Replace the batteries with new ones before the number of openings is reached.

3. **Anti-peeping password function:** when opening the door with the password, enter the password as follows: XXX password XXX; you can add additional codes before and after the password, then press # to confirm. The password must be included in the input content.
4. If no operation is performed for more than 10 seconds, the system will automatically terminate.
5. **Initialization setting:** press the factory reset key under the battery cover on the rear panel of the lock for about 6–8 seconds, and all unlock information and records will be erased after initialization (this operation should be used with caution).
6. **Normal open mode in closed state:** press 5#, a voice prompt will inform you to enter the unlock information.
7. **Normal open mode in open state:** press 5#, a voice prompt will inform you to activate the mode.
8. **Anti-lock function:** When the locking key is pressed again, a voice prompt will inform you that the door is closed. In this mode, normal users cannot access and only administrators can unlock the lock.