

# User Manual

---

RFID card access  
keypad and password  
**SecureEntry-AC700LF**

# Table of contents

- Specifications: ..... 3
- Set contents:..... 4
- Features: ..... 4
- Introduction..... 5
- Installation..... 5
- Connection..... 6
- Drawing Connection Diagram .....7
- Programming.....7
  - Entering the Preset Mode..... 7
  - Set the master code..... 7
  - Setting the Wiegand output format ..... 8
  - Setting the PIN format..... 8
  - Setting the keyboard backlight..... 8
  - Factory reset..... 9
- Function Table..... 9
- PIN Output Format.....10

## Specifications:

- **Warranty:** 1 year
- **Material:** ABS
- **Verification Type:** RFID Card, Password
- **Device type:** RFID card access keypad and password
- **Number of buttons:** 12
- **Keyboard and keys:** silicone keys
- **Reading distance:** 3 ~8 cm
- **Cards read:** EM
- **Operating frequency:** 125 kHz
- **Interface:** Wiegand 26
- **Access control:** yes
- **Working Voltage:** DC 12~18V
- **Standby Current:**  $\leq 35\text{mA}$
- **Ingress Protection:** IP66
- **Operating temperature:**  $-40^{\circ}\text{C} \sim 60^{\circ}\text{C}$
- **Operating Humidity:** 0%~95%
- **Product dimensions:** 12.2 x 5 x 2.1 cm
- **Package dimensions:** 13 x 7.5 x 5.5 cm
- **Product weight:** 155 g
- **Weight with packaging:** 210 g

## Set contents:

- RFID access keypad with cables
- Screws and mounting pins
- Special Key
- Manual

## Features:

- The robust design and IP66 rating make the units resistant to water streaks, so they can be mounted at the entrance of a building
- The access keypad has a built-in RFID card reader, which, when combined with an electronic lock, allows you to open the door not only after entering the password, but also after reading the card
- The device supports DC 12 ~18V and 125 kHz frequency
- Compact and lightweight

## Introduction

The device is an access keypad with a Wiegand output and an integrated proximity reader, and thanks to its water resistance, it can be installed both indoors and in harsh environmental conditions.

### Features:

- Resistant to water ingress, IP66 compliant
- Programmable Wiegand output: 26~37 bits
- Programmable keyboard transmission: 4-bit, 8-bit, or virtual card number format
- External LED and buzzer control

## Installation

- Drill 2 holes (A, C) on the wall for screws and one hole (B) for the cable.
- Drive the rubber pins into the holes (A, C).
- Attach the back cover to the wall using 2 screws.
- Pull the cable through the cable hole (B).
- Attach the appliance to the back cover.

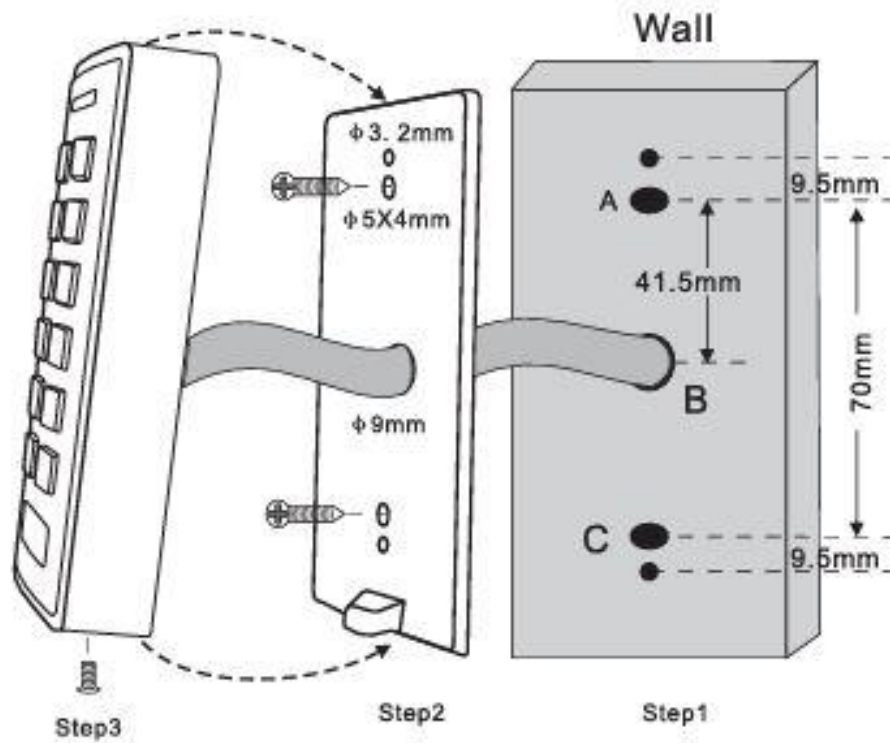

## Connection

Colour	Function	Comments
Red	Power +	+DC (9~18V DC)
Black	GND	Ground
Green	D0	Date 0
White	D1	Date 1
Brown	LED	Green LED Control
Yellow	Buzzer	Buzzer control

## Drawing Connection Diagram

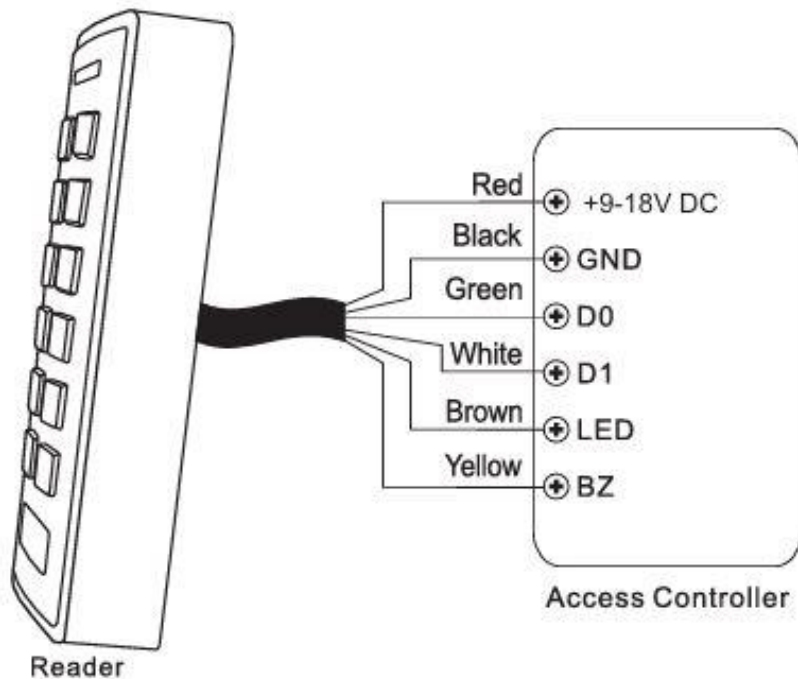

## Programming

Change the configuration settings according to the app (optional). Multiple configuration settings can be changed at the same time: enter programming mode, change the desired settings, and then exit programming mode.

### Entering the Preset Mode

Press **\*** for 5 seconds until you hear a beep, enter **the master code #**

### Set the master code

A master code of 4-6 digits is used to prevent unauthorized access to the system. To connect to the keyboard reader, the manager will need the master code (factory default code 1234).

We recommend that you update immediately and register a new master code.

Programming step	Key Combination
Entering Programming Mode	* (Master Code) #
Master Code Update	0 (New Master Code) # Repeat New Master Code) # (Master Code Is 4-6 Digits)
Exit Programming Mode	*

Setting the Wiegand output format

Programming step	Key Combination
Entering Programming Mode	* (Master Code) #
Format settings	1 (26-37) # (Factory default: 26 bits for EM 125 kHz)
Exit Programming Mode	*

Setting the PIN format

Programming step	Key Combination
Entering Programming Mode	* (Master Code) #
Format settings	2 0# (Virtual Card Number) 2 4# (4 bits, default) 2 8# (8 bits)
Exit Programming Mode	*

Setting the keyboard backlight

Programming step	Key Combination
Entering Programming Mode	* (Master Code) #



Automatic shutdown	3 0# (The backlight will turn off after 20s inactivity)
On all the time	3 1# (default)
Disabled	3 2 #
Exit Programming Mode	*

## Factory reset

Turn off the power, press "\*" and hold, then turn on the power, release the \* key until you hear 3 beeps.

## Function Table

Card reading	The LED will illuminate green and the buzzer will beep. meanwhile, the reader sends a Wiegand signal
External LED control	When the input voltage for the LED is low, the LED will turn green
External buzzer control	When the input voltage of the buzzer is low, the buzzer will make a sound
Wiegand Data Output	Wiegand 26~37 bits available for the reader. Factory default settings: 26 bits.

## PIN Output Format

The default keyboard transmission format is 4 bits, 8 bits, or a virtual card number format, which can be customized.

- **4 bits**

The reader will transmit PIN data each time a key is pressed:

1 (0001), 2 (0010), 3 (0011)

4 (0100), 5 (0101), 6 (0110)

7 (0111), 8 (1000), 9 (1001)

\* (1010), 0 (0000), # (1011)

- **8 bits**

The reader will transmit PIN data each time a key is pressed:

1 (1110 0001), 2 (1101 0010), 3 (1100 0011)

4 (1011 0100), 5 (1010 0101), 6 (1001 0110)

7 (1000 0111), 8 (0111 1000), 9 (0110 1001)

\* (0101 1010), 0 (1111 0000), # (0100 1011)

- **Virtual card number**

The reader will transmit the PIN data when the last key (#) after the PIN is pressed.

**Example:** PIN: 999999. Press 999999# and then the output format will be 0000999999.