

User Manual

RFID Access Control Reader **SecureEntry-AC500**

Table of contents

- Specifications: 3
- Set contents:..... 4
- Features: 4
- Kit Parts List..... 5
- Short programming guide 5
- Installation..... 6
- Connection diagram.....7
- Factory reset..... 9
- Sound and light signalling..... 9
- Detailed programming instructions.....10
 - 1. User settings 10
 - 2. Door Lock Settings..... 14
- Device connection as Wiegand output reader.....16

Specifications:

- **Warranty:** 1 year
- **Material:** durable zinc alloy
- **Color:** Silver
- **Supported RFID cards:** EM
- **Operating frequency:** 125 kHz
- **Device Type:** RFID Card and Password Access Control Reader
- **Verification Type:** RFID Card, Password
- **Reading distance:** > 10 cm
- **Number of buttons:** 13
- **Access control:** yes
- **Working Voltage:** DC12V
- **Static Current:** < 8mA
- **Lock opening current:** < 1000mA
- **Interface:** Wiegand 26
- **Ingress Protection:** IP65
- **Operating temperature:** -10°C - 70°C
- **Operating Humidity:** 10% - 90%
- **Product dimensions:** 12 x 1.8 x 5.6 cm
- **Package dimensions:** 19.2 x 12.8 x 6.1 cm
- **Product weight:** 500 g
- **Product weight with packaging:** 700 g

Set contents:

- Access Control Reader
- Screws and mounting pins
- Special Key
- Manual

Features:

- Robust and durable housing to resist water ingress
- Authorization with RFID card and password
- 125 kHz RFID Card Reading
- Operating voltage of DC12V
- Can be combined with a doorbell and electronic lock

Kit Parts List

Name	Quantity	Comments
Keyboard	1	
Manual	1	
Screwdriver	1	Φ20mm×60mm, special for reader
Rubber plug	2	Φ6mm×30mm, used for fixing
Self-Tapping Screws	2	Φ4mm × 28mm, used for fixing
Phillips Screw	1	Φ3mm×6mm, used for fixing

Short programming guide

Entering Programming Mode	* master code # 999999 is the default master code
Exit Programming Mode	*
Please note that the master user must be logged in to perform the following programming	
Changing the master code	0 new code # new code # Master code can be 6 to 8 digits long
Add a user PIN	1 User ID # PIN # The ID number is any digit between 1 and 2000. A PIN is any four digits between 0000 and 9999 except for 1234, which is booked. Users can be added continuously without exiting programming mode

Add a user card	1 Card reading # Cards can be added continuously without leaving the programming mode
Delete a user PIN or card	2 user ID # for user PIN 2 card reading # for user card Users can be deleted continuously without exiting programming mode
Unlocking the door with a PIN code	Enter your PIN, then press #
Unlocking the door with an RFID card	Hold the card to read

Installation

- Remove the back cover of the device using the special screwdriver provided.
- Drill 2 holes in the wall for the self-tapping screws and a hole for the wire.
- Place the provided rubber caps into the two holes.
- Secure the back cover to the wall using 2 self-tapping screws.
- Pull the cable through the cord hole.
- Attach the reader to the back cover.

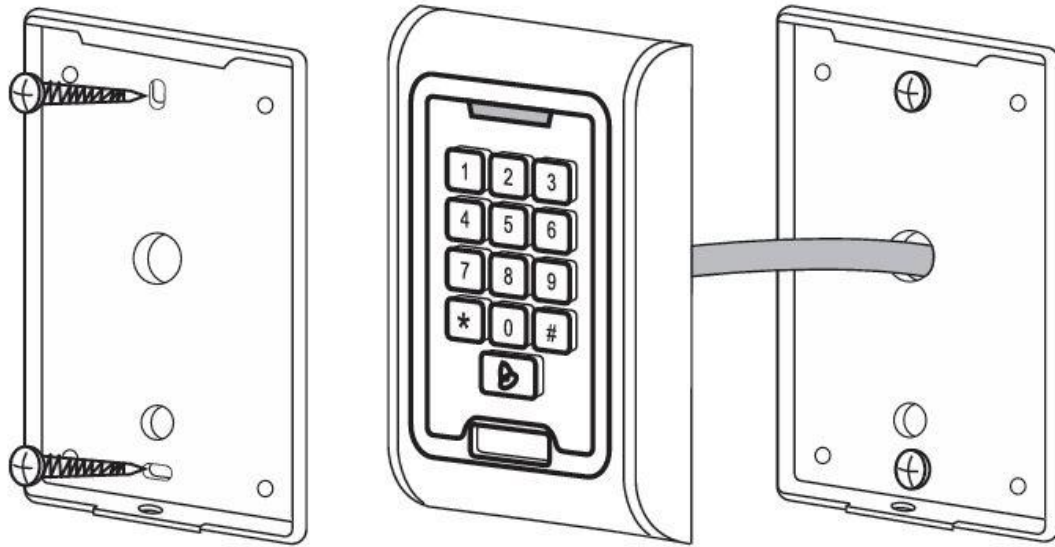

Connection diagram

Colour	Function	Description
Pink	BELL_A	Doorbell button on one end (optional)
Pink	BELL_B	Doorbell button on the other end (optional)
Green	D0	Wiegand D0 output
White	D1	Wiegand D1 output
Yellow	OPEN	Exit button on one end (other end connected to GND)
Red	12V+	Adjustable 12V+DC power input
Black	GND	Adjustable 12V DC power input

Blue	YES	Relay normally on (connecting positive electrical interlock "-")
Violet	COM	Relay End, GND connection
Orange	NC	Relay end closed (negative electrical interlock connection "-")

Common Power Supply Diagram

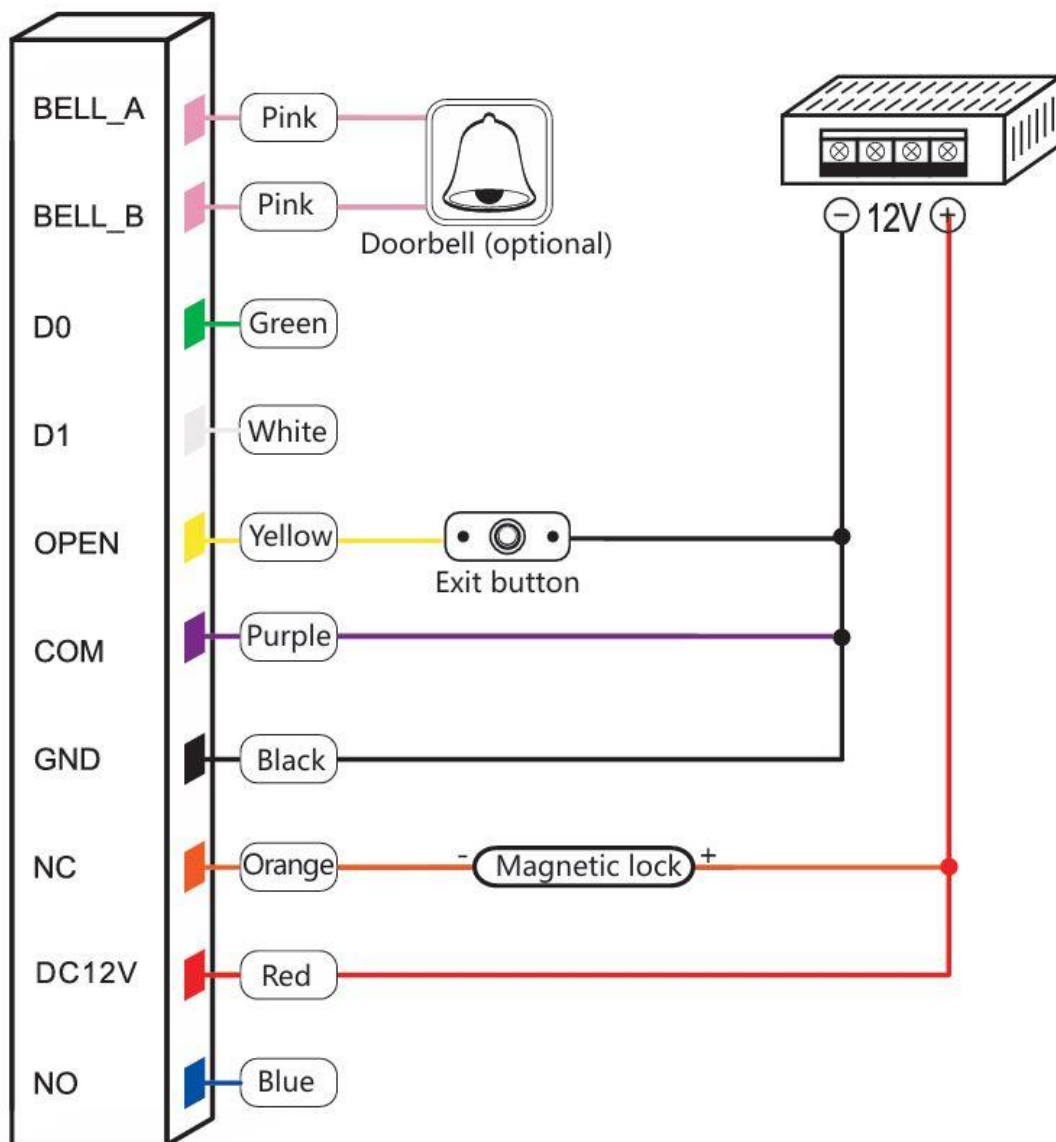

Connection diagram with special power supply

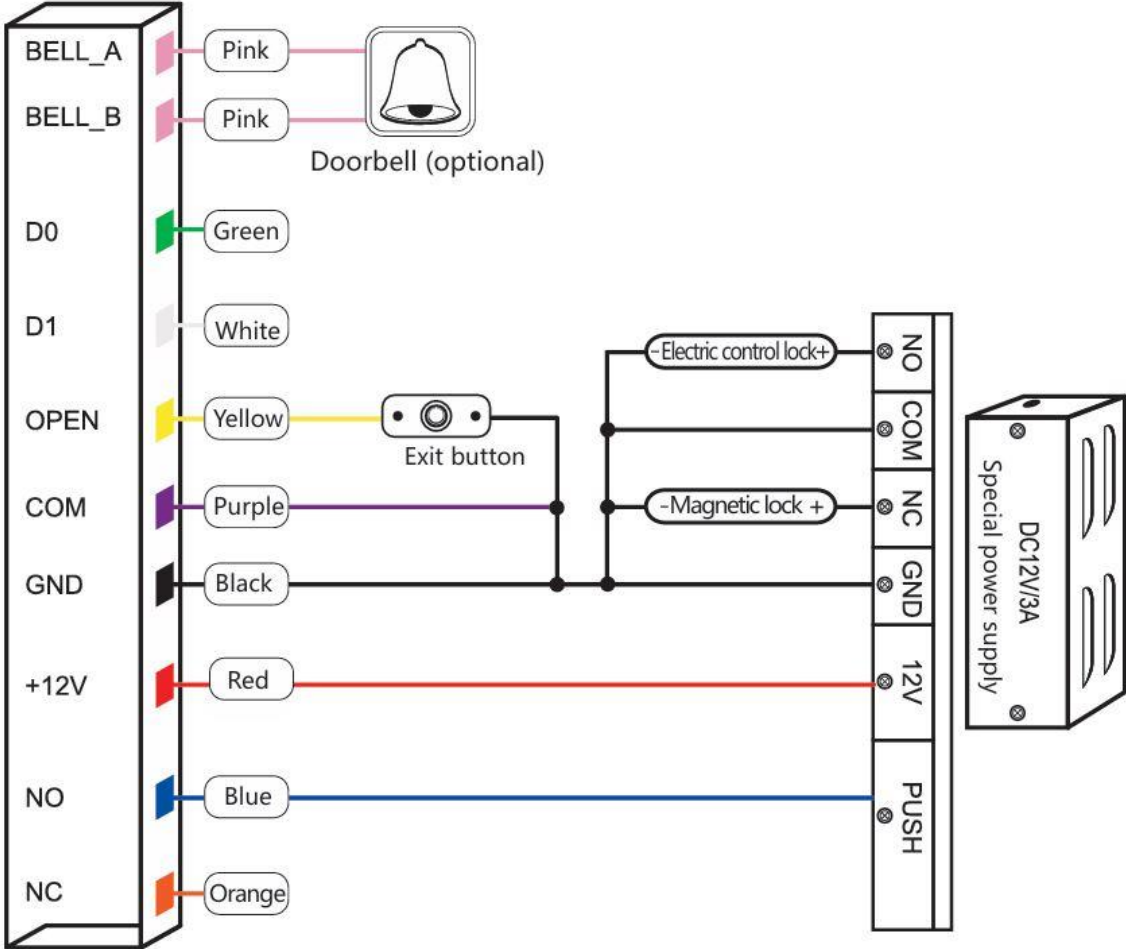

Factory reset

- Turn off the power
- Press and hold the # button while powering on
- After hearing the double click, release the # button, the system will return to factory settings.

Registered users will not be deleted after a factory reset.

Sound and light signalling

Operation Status	LED Color	Beep
Standby	Red LED flashes slowly	
Numeric keypad		One short click
Operation correct	Green LED	One long click
Operation invalid		3 short clicks
Entering Programming Mode	Red LED	One long click
Programming status	Orange LED	
Exit Programming Mode	Red LED flashes slowly	One long click
Unlocking the door	Green LED	One long click
Alarm	The red LED flashes quickly	Alarm signal

Detailed programming instructions

1. User settings

- **Entering Programming Mode:**

* **Master code # 999999** is the default master code

- **Exit Programming Mode:**

*

Please note that the master user must be logged in to perform the following programming.

- **Master code change:**

0 new code # new code # Master code should be between 6 and 8 digits long

- **Setting the operating mode:**

- Setting the door to unlock only via the card:

3 0# Door Opening With RFID Card Only

- setting the door to be unlocked with a card and user PIN:

3 1# door opening is by PIN code and RFID card

- Setting the door to unlock with a card or user PIN:

3 2# door opening is done by card or PIN code (default)

Adding a user in card or PIN mode, i.e. **3 2# mode.** (Default Settings)

- To add a user PIN:

1 User ID # PIN code #

An ID number is any number between 1 and 2000.

A PIN is any four digits between 0000 and 9999, except for 1234, which is reserved.

Users can be added continuously without exiting programming mode as follows:

1 First User ID # PIN # Second User ID # PIN #

- To remove a user PIN:

2 User ID # Users can be deleted continuously without exiting programming mode.

- Changing the user PIN code (this step must be performed outside of the programming mode):

*** ID number # Old PIN code # New PIN code # New PIN code #**

- Adding a user card (Method 1):

This is the fastest way to enter cards, automatically generating a user ID number

1 card reading # Cards can be added continuously without exiting programming mode

- Adding a user card (method 2):

This is an alternative way to enter using the assigned user ID number. In this method, a user ID is assigned to a card. Only one user ID can be assigned to a card.

1 ID number # card reading # User can be added continuously without exiting programming mode.

- Adding a user card (method 3):

The card number is the last 8 digits printed on the back of the card, the user ID number is generated automatically.

1 card number # The user can be added continuously without exiting programming mode.

- Delete a user card by card:

Remark. Users can be removed continuously without exiting programming mode.

2 Card Reading #

- Deleting a user card by user ID:

This option can be used when the user has lost their card.

2 User ID number

- **Deleting a user card by card number:**

This option can be used when a user wants to make a change, but the card is lost.

2 Card number

Note: Users can be deleted continuously without exiting development mode.

Adding a card and user PIN in card and PIN mode (3 1#)

- **Adding a card and user PIN:**

The PIN is any four digits between 0000 and 9999 except for 1234, which is reserved.

- Add a user card
- Press * to exit the programming mode.
- Then assign a PIN code to the card as follows:

* 1234# PIN card reading # PIN

- **Changing the PIN code in Card and PIN mode (Method 1):**

Please note that this is done outside of the programming mode, so the user can perform this operation on their own.

* card reading Old PIN code # New PIN code # New PIN code

- **Changing the PIN in Card and PIN Mode (Method 2):**

Please note that this is done outside of the programming mode, so the user can perform this operation on their own.

* ID number # Old PIN code # New PIN code # New PIN code

- **Deleting the card and user PIN:**

2 ID Number #

Adding a card user in card mode (**3 0#**)

- To add or remove a user card:

The operation is the same as adding and removing a card user in **3 2#**

- Delete all users:

Keep in mind that this is an irreversible option, so you should use it wisely.

2 0000 #

Unlocking the door:

- With a PIN:

Enter your PIN **number on the keypad** and press **#**

- With an RFID card:

Read card

- With your card and PIN:

Read the card and then enter **the PIN #**

2. Door Lock Settings

Relay output delay time:

- Door opening time setting:

*** Master code #4 0~99#** 0-99 is the range of seconds used to set the time.

Alarm Output Signal Time:

- Alarm Output Time Setting (0-3 minutes):

The factory default setting is 1 minute.

5 0~3 #

Keypad lock and beep activation:

If 10 invalid cards or 10 invalid PIN numbers appear within 10 minutes, the keypad will lock for 10 minutes and the internal beep will work for 10 minutes, depending on the option selected below.

- **Normal condition:**

No keypad lock or beep works (factory default).

7 0# factory setting.

- **Keypad:**

7 1 #

- **Internal beep activated:**

7 2 #

Device connection as Wiegand output reader

The device supports 26-bit Wiegand output, so Wiegand data cables can be connected to any controller that supports 26-bit Wiegand input.

