

Manual

Label printer **Oprint-XD200N**

Table of contents

- Specifications: 3
- Set contents: 5
- Printer components: 5
- Installation: 6
 - Printer Installation** 6
 - Label Installation** 6
- LED Indicator and Button Functions: 8
 - Led** 8
 - General Button Functions** 9
 - Starter Functions** 9
 - Gap/black line detection** 10
 - Gap/black line detection, printing self-test values and entering debug mode** 11
 - Label Paper Calibration Instruction: 11
 - Self-test 12
 - Debug Mode 12
 - Initializing the printer** 13
 - Skipping the AUTO program. BASS** 14
- Diagnostic tool: 15
 - Enable the Diagnostic Tool** 15
 - Printer Settings** 16
 - Calibrating the Paper Sensor with the Diagnostic Tool** 17
 - Auto Correction: 17
 - Printer IP Address Configuration** 18
 - Completing the setup** 18
 - Additional Features** 19
- Troubleshooting: 19
- Printer maintenance procedures: 24
 - Cleaning and Maintaining the Printer with Tools** 24
 - Cleaning Steps** 24

Specifications:

- **Warranty:** 1 year
- **Resolution:** 203 dpi
- **Printing Method:** Thermal Printing
- **Max. print speed:** 152 mm (6") / sec.
- **Max print width:** 108 mm (4.25")
- **Max. print length:** 1778 mm
- **Media Type:** Continuous, Intermittent, Black Mark, Folded and Punched
- **Media Width:** 26mm~116mm
- **Media Thickness:** 0.06~0.254mm (2.36~10mil)
- **Media Core Diameter:** 25.4~76.2mm (1"~3")
- **Label Length:** 10mm~1778mm
- **Print head life:** 50km
- **Sensors:** gap sensor; Lid open sensor; Black mark sensor
- **Swivel:** 0°, 90°, 180°, 270°
- **Interface:** USB+Lan
- **Printer Command Language:** TSPL, EPL, ZPL, DPL
- **Driver:** Windows/Linux/Mac
- **SDK:** Windows/ Android/ iOS
- **Processor:** 32-bit processor
- **Memory:** 8 MB Flash, 8 MB SDRAM, Flash memory can be expanded to a maximum of 4 GB
- **Operating Voltage:** AC 110-240V
- **Device dimensions:** 21.5 x 17.8 x 15.5 cm
- **Package dimensions:** 21 x 29 x 19 cm
- **Device weight:** 1.3 kg
- **Weight with packaging:** 2.1 kg
- **Operating Temperature:** 5~40°C
- **Storage Temperature:** -40~60°C
- **Operating Humidity:** 25~85% non-condensing
- **Storage Humidity:** 10~90% non-condensing

- **Printed 1D codes:** Code 39, Code 93, Code 128UCC, Code 128 subsets A, B, C, Codabar, Interleaved 2 of 5, EAN-8, EAN-13, EAN-128, UPC-A, UPC-E, EAN and UPC 2(5) digits add-on, MSI, PLESSEY, POSTNET, China POST, GS1 DataBar, Code 11
- **2D printed codes:** PDF-417, Maxicode, DataMatrix, QR, Aztec

Set contents:

- Label printer,
- label roll,
- USB cable,
- power supply
- Manual.

Printer components:

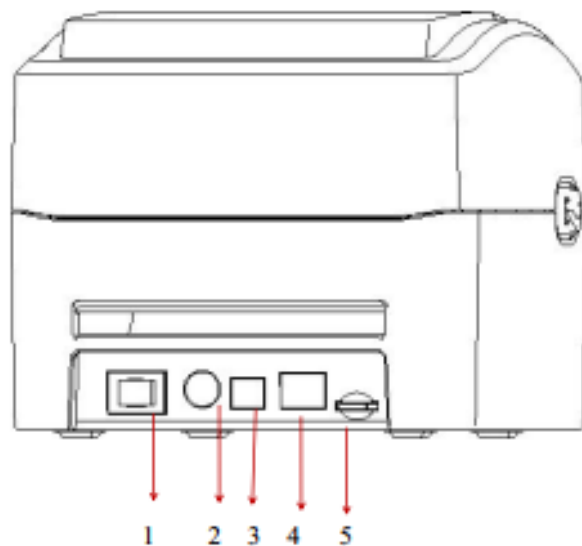
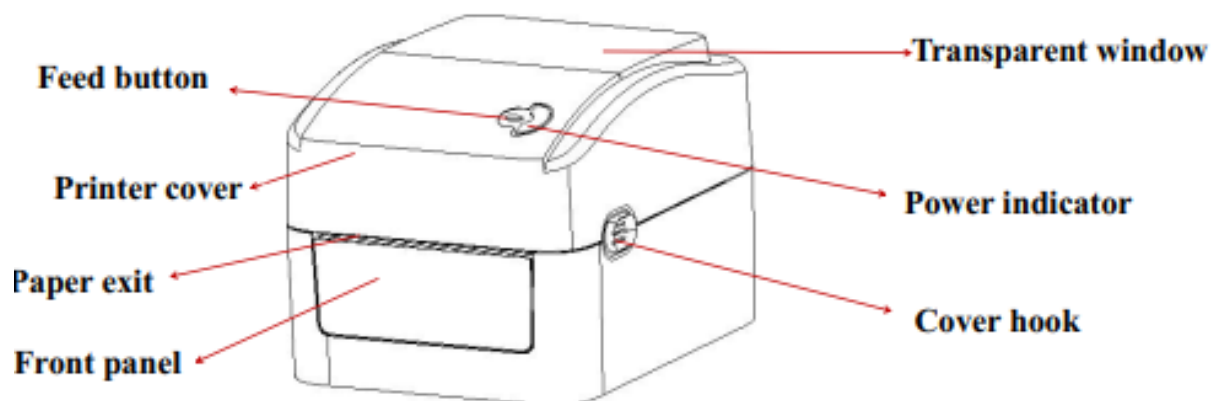

1. Power switch
2. Power socket
3. USB interface
4. Ethernet interface
5. SD card slot

Installation:

Printer Installation

1. Place the printer on a smooth and stable surface and make sure it is turned off.
2. Plug one end of the parallel port cable, serial port cable, or USB cable into the appropriate slot on the back of the printer, and plug the other end into the correct slot on your computer.
3. Plug the power cord into the power outlet on the back of the printer, and then slide the other end into a power outlet.

Note: Make sure the printer is turned off before plugging the power cord into the power outlet on the back of the printer.

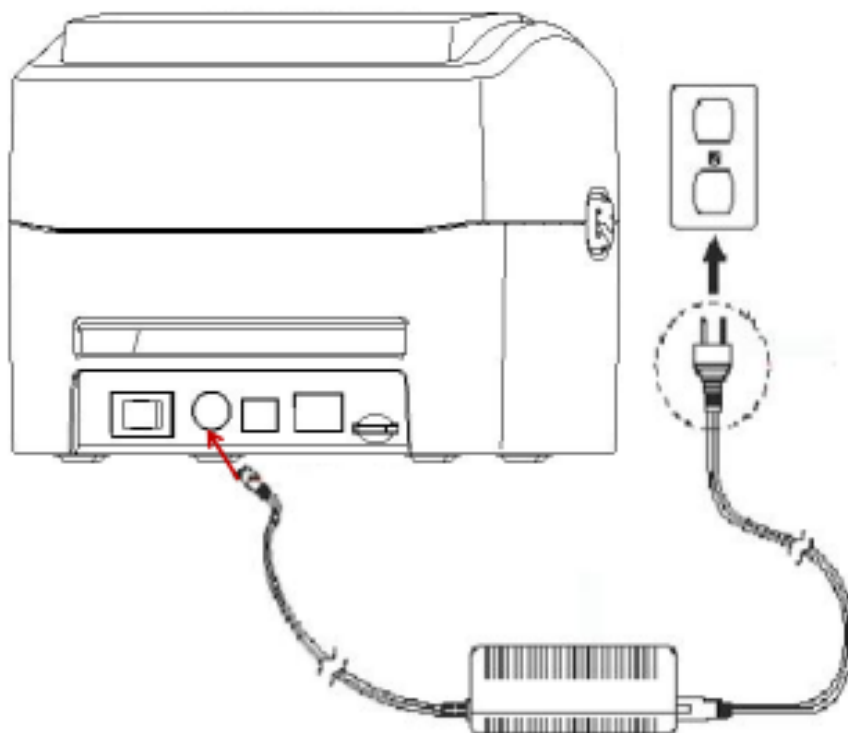

Label Installation

1. Install the label in the paper feed kit (fixing plate and paper roll roller).

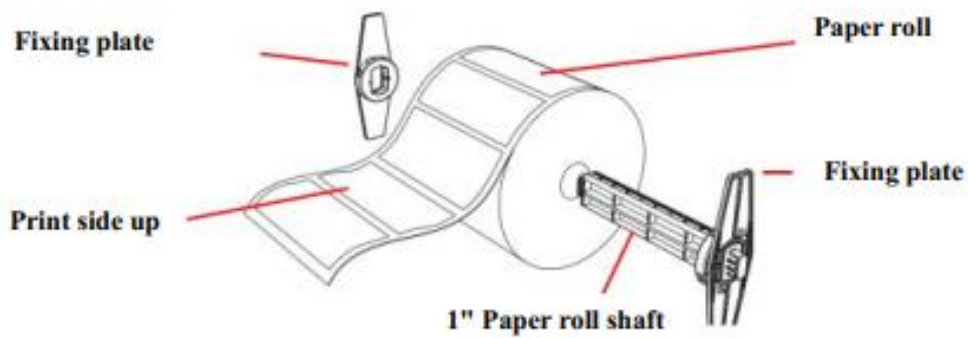

2. Push the printer cover tab forward with both hands to open the printer cover.
3. Place the label roll in the paper roll holder (the print side facing up).
4. Put the label through the paper guide and pull it over the rubber roller.

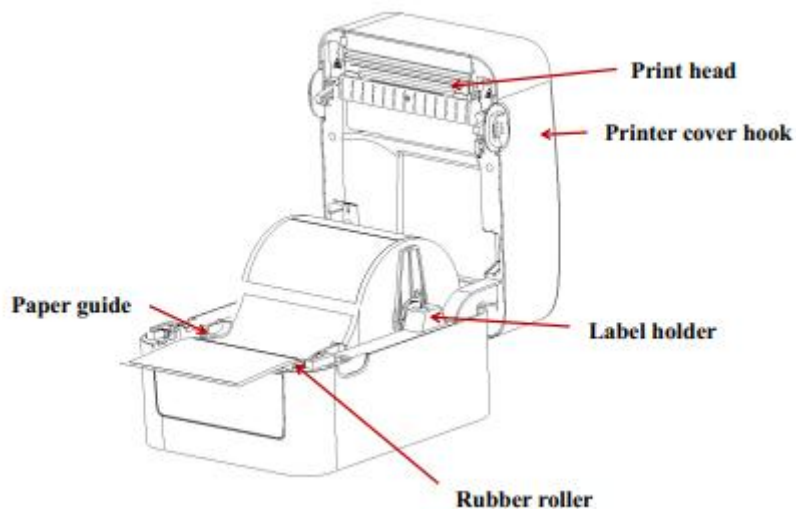

5. Close the printer cover.

Note: To avoid degrading print quality, make sure the printer cover is closed securely.

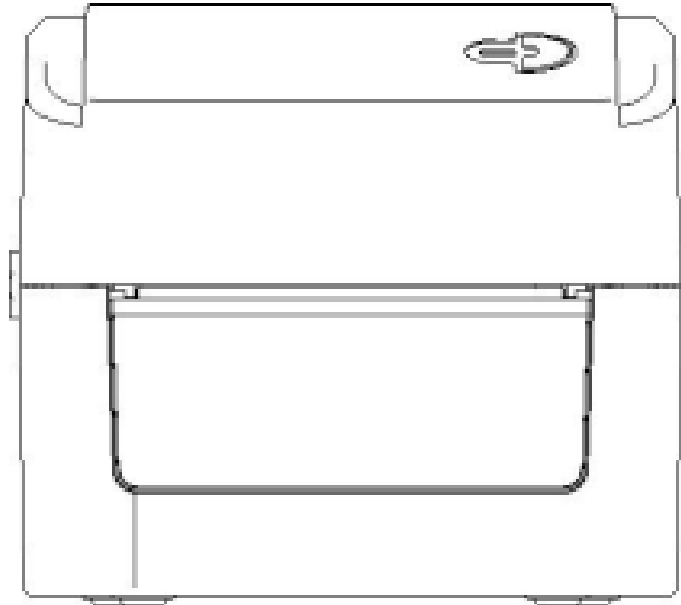

LED Indicator and Button Functions:

The printer has one button and one indicator that can display three colors. Pressing a button in combination with different colors or in conjunction with the power switch allows you to activate various printer functions such as paper feed, pause the printer, calibrate the label sensor, print self-test values, and initialize the printer.

Led

LED Indicator Color	Description
Blue (Fixed)	Power on, printer in print standby mode.
Blue (flashing)	The printer is downloading data or is paused.
Violet	The printer formats the data.
Red (solid)	The printer is open or in cutter error mode.
Red (flashing)	A printing error has occurred, such as out of paper, paper jam, or memory error.

General Button Functions

1. Paper Feed

- When the printer is in standby mode (LED is blue), pressing the paper feed button moves the paper forward one step.

2. Pausing the printer

- While printing, pressing the paper feed button pauses the operation. At this point, the power indicator flashes blue. Pressing the button again resumes printing.

Starter Functions

The printer has four startup functions that can be used to set up or test the hardware.

Procedure for starting the start function:

1. Turn off the printer.
2. Turn on the printer by holding down the button.
3. Release the button when the indicator light indicates the desired function (as shown in the table below).

Startup function	Pointer Color Cycle Mode
1. Gap/black line detection	Purple → Blue (flashes 5 times) → Button release
2. Gap/black line detection, printing self-test value and entering debug mode	Purple → Blue (flashes 5 times) → Red (flashes 5 times) → Button release
3. Initialize the printer (factory reset)	Purple → Blue (flashes 5 times) → Red (flashes 5 times) → Purple (flashes 5 times) → Button release

4. Skipping the AUTO program. BASS	Purple → Blue (flashes 5 times) → Red (flashes 5 times) → Purple (flashes 5 times) → Blue (solid) → Button release
------------------------------------	--

Gap/black line detection

This test determines the sensitivity of the label sensor when the printer is turned on. If you install a new paper roll with a different specification or initialize the printer to factory settings, the paper sensor must be recalibrated.

Gap or black line detection calibration will be performed using the latest test value as a reference value. By default, the printer sensor is set to gap calibration.

Please follow the steps below to calibrate the ribbon and the gap/black line sensor:

1. Turn off the printer.
2. Turn on the printer while holding down the paper feed button.
3. When the indicator flashes purple for the first time, release the paper feed button.

4. **Pointer Color Cycle Mode:**

- Purple → Blue → Red (flashes 5 times) → Purple (flashes 5 times) → Blue (flashes 5 times) → Blue (solid)

NoteWhether

the paper sensor detects a gap or a black line depends on the **GAP** or **BLINE** command sent to the printer (with the last value set as the reference value). By default, the printer is set to gap calibration. For more information about **the GAP** and **BLINE**

commands, please refer to **the TSPL2 Programming Guide**.

Gap/black line detection, printing self-test values and entering debug mode

This test determines the sensitivity of the label sensor when the printer is turned on. If you install a new paper roll with a different specification or restore the printer to factory settings, the paper sensor must be recalibrated.

Gap or black line detection calibration will be completed using the latest test value as a reference value. The default value of the printer sensor is **gap calibration**.

Label Paper Calibration Instruction:

1. Make sure that the label paper is loaded correctly.
2. Turn off the printer.
3. Turn on the printer by holding down the paper feed button.
4. When the LED indicator flashes purple for the first time, release the paper feed button.

5. Pointer Color Cycle Mode:

- Purple → Blue → Red (flashes 5 times) → Purple (flashes 5 times) → Blue (flashes 5 times) → Blue (solid)
6. The sensor will calibrate the paper and the printer will print a self-test value and enter debug mode.
 7. Turn the printer off and on again to return it to normal print mode.

Note:

Before calibrating the label sensor, you must first confirm the

type of label you want to detect using the **Diagnostic Tool or the GAP/BLINE command**. For more information on these commands, see **the TSPL2 Programming Guide**.

Self-test

When the sensor calibration is complete, the printer prints the self-test value. Before connecting the printer to the computer, you can use a self-test to confirm that the printer is working properly. The self-test printout can also be used to check the print quality of the printhead and the internal settings of the printer.

Debug Mode

After the self-test is printed, the printer system enters debug mode. In this mode, all volume labels will be printed as machine code.

The ASCII strings on the left are the data received by the system. The data on the right is printed from the strings on the left as hexadecimal values.

This feature is intended for users or engineers to debug programs. To exit debug mode and return to normal print mode, simply restart the printer.

Remark:

1. A 4" **wide label is required to print all data in debug mode**.
2. To exit debug mode and return to normal print mode, restart **the printer** or press **the PAPER FEED** button to enter standby mode.

Initializing the printer

The printer initialization function is used to delete downloaded files from memory (DRAM) and restore the printing parameters to factory settings.

Printer initialization instructions:

1. Turn off the printer.
2. Hold down the paper feed button and turn on the printer. At this point, the color of the indicator will change in the following sequence:

Pointer Color Cycle Mode:

- Purple → Blue → Red (flashes 5 times) → Purple (flashes 5 times) → Blue (flashes 5 times) → Blue (solid)
3. Release the paper feed button when the LED indicator flashes blue.
 - At this point, the printer will be reset.
 - The LED indicator will flash **purple** once.
 - Finally, the LED indicator will light up **blue**, indicating standby mode.

Parameters	Default values
Velocity	152.0 mm/sec (6 ips) (203 DPI)
Density	8
Label width	4" (100 mm)
Label height	7.9" (180 mm)
Sensor Type	Gap Sensor
Slot Setting	0.16 in. (4.0 mm)

Printing direction	-
Reference	0.0 (top left)
Translation	0
Tear-off mode	Enabled
Peel mode	Disabled
Characters	850
Country code	001
Cleaning the flash drive	No
IP address	DHCP

Skipping the AUTO program. BASS

The TSPL2 **command language** allows the user to load an autorun file (**AUTO. BASS**). When you turn on the printer, this file will be automatically executed according to its contents. If you want to skip the **AUTO. BAS** after the printer boots up, you can use this startup function to ignore the auto-executable file.

Instructions for skipping the AUTO program. BASS:

1. Turn off the printer.
2. Hold down the paper feed button and turn on the printer.
The LED indicator will start changing colors in the following order:

Pointer Color Cycle Mode:

- Purple → Blue → Red (flashes 5 times) → Purple (flashes 5 times) → Blue (flashes 5 times) → Blue (solid)
3. Release the **PAPER FEED button** when the LED indicator is **solid blue**.
 4. The printer skips the **AUTO program. BAS** was also used.

Diagnostic tool:

Diagnostic Tool is an easy-to-use utility program for Windows that allows you to check the current status and settings of your printer, download image files, programs, font files, etc., and perform full firmware updates as needed.

In addition, it supports creating and downloading matrix fonts, uploading commands or files, and many other features. With it, you can **complete your printer configuration, check its status, and troubleshoot usage issues more easily.**

Enable the Diagnostic Tool

1. **Move the mouse cursor** over the **Diagnostic Tool.exe** icon and double-click it with the left mouse button.
2. When you launch the program, four management pages **will appear on the home screen:**
 - **Printer Settings**
 - **File management**
 - **Communication tools**
 - **Printer system settings**

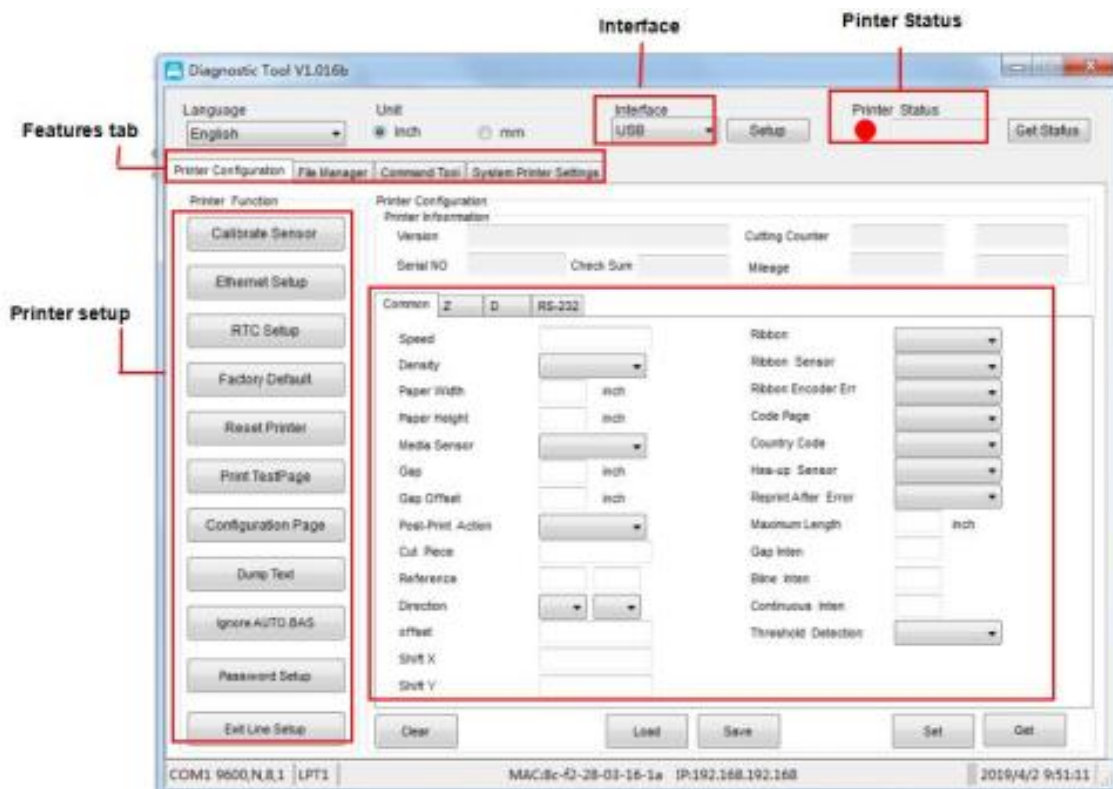

Printer Settings

1. Select the interface between the computer and the printer. The default communication interface in **the Diagnostic Tool** is **USB**, so if your computer is connected via a USB cable, you do not need to make any changes to the settings.

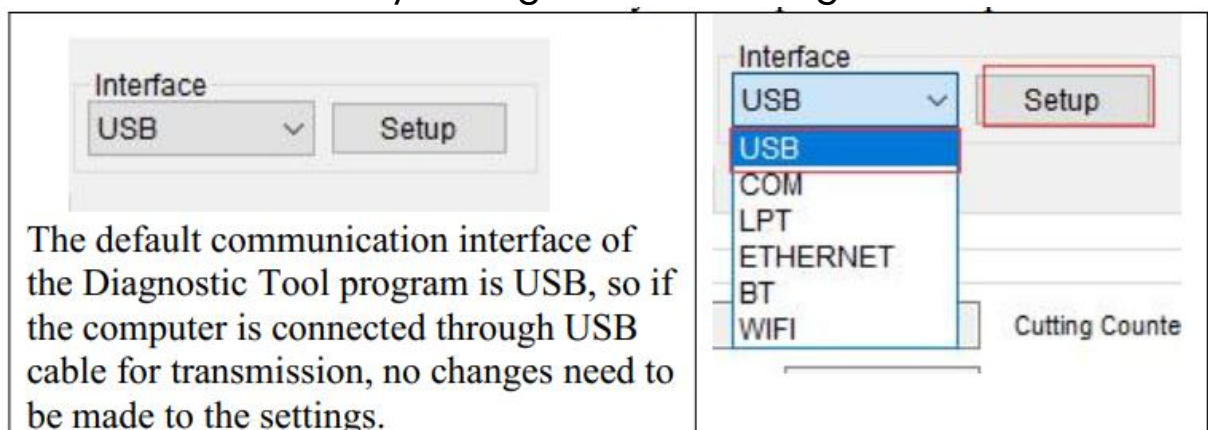

2. Click on the function you want to set in the "**Printer Settings**" tab.

3. Features available in the "Printer Settings" section:

	Description
Printer Function Calibrate Sensor	Sensor Calibration
Ethernet Setup	Set Ethernet Network
RTC Setup	Set Printer RTC Time Parameters
Factory Default	Restore Factory Defaults and Reboot
Reset Printer	Restart the Printer
Print TestPage	Print Test Page
Configuration Page	Print Self-test Page
Dump Text	Enter Printer Debugging Mode
Ignore AUTO.BAS	Ignore the AUTO.BAS File
Password Setup	Set the Diagnostic Tool Password
Exit Line Setup	

Calibrating the Paper Sensor with the Diagnostic Tool Auto Correction:

1. **Make sure** the paper is properly loaded and the print head is closed.
2. **Turn on the printer.**
3. **Launch the Diagnostic Tool** and set the transmission interface (**USB by default**).

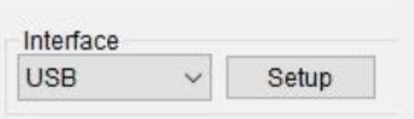

The default communication interface of the Diagnostic Tool program is USB, so if the computer is connected through USB cable for transmission, no changes need to be made to the settings.

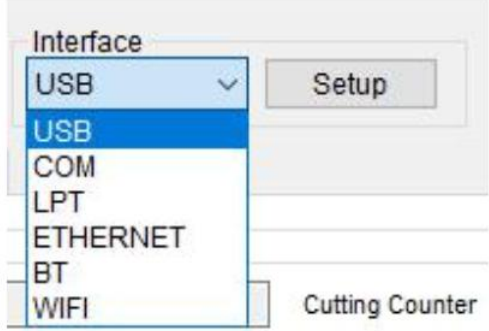

4. **Click on "Sensor Calibration".**

5. **Select the paper type** and click "**Calibration**". The printer will automatically move the paper to perform sensor calibration.

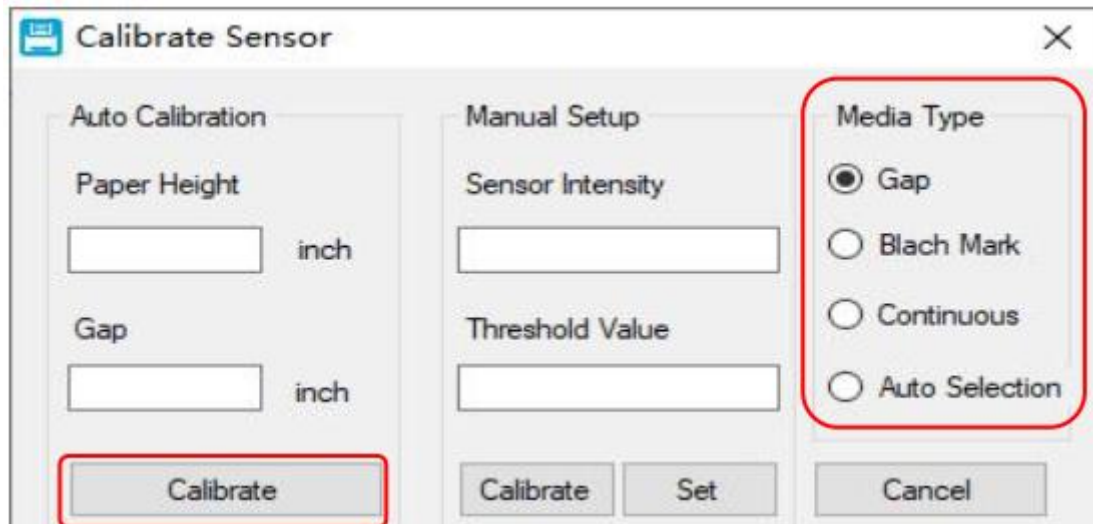

Printer IP Address Configuration

The default IP factory setting is "**Automatically retrieve IP location**" (DHCP).

If you want to **change the IP address**, follow these steps:

1. **Select** "Designate the IP location".
2. **Enter values:**
 - o **IP address**
 - o **Subnet mask**
 - o **Gateway**
3. **Click the "Set IP" button** to assign a new address.
4. If you want to change **the name of the printer**, enter the new name in the "Printer Name" field and then click "**Set Printer Name**".

Note: When you press the "**Set Printer Name**" or "**Set IP**" button, the printer will be reset.

Completing the setup

Click "**Exit**" to close the TCP/IP settings and return to the main screen of the **Diagnostic Tool**.

Additional Features

- **"Factory default value"** – Restores the factory default settings of the IP address (automatic acquisition of the IP address – DHCP).
- **"Webpage setting"** – Allows you to configure, update the software, and manage your printer using a web browser (Internet Explorer or Firefox). With this feature, the user can **remotely manage the printer over a local area network (LAN)**.

Troubleshooting:

The following table shows the most common problems that printer users may encounter and suggested solutions. If the printer is still not working properly after following the suggested steps, contact the vendor's customer service for further assistance.

Problem	Cause	Solution
The power indicator is not lit	- The power plug and outlet are not properly connected to the printer.- The printer is not turned on.	- Check the power connection and make sure the plug and socket are plugged in properly.- Turn on the printer.
Diagnostic Tool displays "Head open"	- The printer cover is not closed.	- Close the printer cover.
Diagnostic Tool displays "Paper end"	- Paper has run out.- Paper installation incorrectly.- Sensor	- Load a new paper roll.- Check the correct paper installation and perform a reinstallation.-

	position incorrectly.	Calibrate the paper sensor.
Diagnostic Tool displays "Paper Jam"	- Incorrect sensor settings.- Incorrect label size.- Paper may be stuck inside the printer mechanism.	- Calibrate the label sensor.- Set the correct label size.- Clean the inside of the printer mechanism.
Can't print	- The serial cable plug in the machine socket is not 1 to 1 type.	- Reconnect the transmission line. - Replace the serial port cable. Make sure the cable has a Type 1 to 1 connector.- Check that the printer's baud rate is set to 9600, n,8,1. - Replace the cable with one that complies with the 1 to 1 standard. - Replace the cable with a new one. - Clean the print head. - Adjust the print density settings. - Turn off the printer, and then reconnect the printhead cable. - Check the stepper motor cable connection. - Make sure that the PRINT command terminates with CRLF.

<p>Out of memory space (FLASH/DRAM)</p>	<ul style="list-style-type: none"> - FLASH/DRAM is full. 	<ul style="list-style-type: none"> - Delete junk files in FLASH/DRAM. - DRAM can store up to 256 files. - User can store up to 256 KB in DRAM. - FLASH can store up to 256 files. - Maximum user space in FLASH memory is 2560 KB.
<p>microSD is not available</p>	<ul style="list-style-type: none"> - The microSD card is damaged. - The microSD card is not inserted correctly. - The microSD card is from an unverified manufacturer. 	<ul style="list-style-type: none"> - Use a microSD card with the appropriate capacity. - Remove and reinsert the microSD card. - Use a microSD card from a reputable manufacturer.
<p>Poor print quality</p>	<ul style="list-style-type: none"> - There is dust or glue on the print head. - Incorrect print density. - Defective print head. - Improper setting of the print head pressure. 	<ul style="list-style-type: none"> - Replace used consumables. - Clean the print head. - Clean the rubber roller. - Adjust the density and print speed settings on the printer. - Print a self-test value to see if the print head is faulty. If so, replace it. - Adjust the print head pressure adjustment knob:- If the print on the left side of the label is too bright, increase the

		<p>value on the left side of the knob.- If the value is already "5" but the print is still too bright, turn the dial back to "1" and then adjust the Z-axis adjuster to get the best pressure setting.- If the print on the right side of the label is too bright, increase the value of the right pressure adjustment knob.- If the thickness of the label exceeds 0.22 mm, the print quality may deteriorate – increase the pressure of the print head.- Make sure that the print head holder is closed properly.</p>
Skip labels when printing	<ul style="list-style-type: none"> - Incorrect label size settings. - Change the label without recalibrating the sensor. - The label sensor is covered with dust, resulting in misdetection. 	<ul style="list-style-type: none"> - Make sure that the label size settings are correct. - Recalibrate the sensor. - Remove dust from the sensor using compressed air.
Incorrect print position when	<ul style="list-style-type: none"> - Incorrect label sensor settings.- 	<ul style="list-style-type: none"> - Recalibrate the label sensor.- Set the correct

printing small labels	Incorrect label size settings.- Incorrect vertical label offset setting in the printer driver.	label size and gap width.- If you are using BarTender software, set the vertical offset in the printer driver.
No printing on both sides of the label	- Incorrect label size settings.	- Set the correct label size.
RTC (Real-Time Watch) does not work properly after restarting the printer	- The battery on the motherboard is dead.	- Check the battery on the printer's motherboard.
The problem with label wrinkling	- Uneven print head pressure.- Incorrect label paper installation.- Incorrect print density.- Incorrect paper feeding.	- If the printhead pressure is uneven, adjust the pressure adjustment knob.- Set the appropriate print density.- Use the label width adjuster to match the print width.
Grey lines on black thermal paper	- Dirty print head.- Dirty rubber roller.	- Clean the print head.- Clean the rubber roller.
Non-permanent print	- The printer is in Dump Mode (Hex Dump Mode).- Incorrect serial cable settings (RS-232).	- Power cycle the printer to exit Dump mode.- Reset RS-232 settings.

Printer maintenance procedures:

Cleaning and Maintaining the Printer with Tools

Cotton swabs
Cotton cloth
Vacuum cleaner or compressed air
Medical alcohol

Cleaning Steps

Element	Steps	Recommended frequency
Printhead	1. Turn off the printer. 2. Wait at least 1 minute for the head to cool down. 3. Wipe the surface of the head with a cotton swab dipped in medical alcohol.	When installing a new label paper roll
Rubber roller	1. Turn off the printer. 2. As you rotate the roller, gently wipe it with a cotton cloth or cotton swab dipped in medical alcohol.	When installing a new label paper roll
Paper tear-off edge	Wipe it with a cotton cloth dipped in medical alcohol.	If necessary
Sensor	Remove dust from the sensor using compressed air or a vacuum cleaner.	Once a month
External Printer Enclosure	Wipe with a damp cotton cloth.	If necessary
Inside the printer	Remove dust with a vacuum cleaner or compressed air.	If necessary

Comments:

- **Do not touch the print head directly with your hands.** If you accidentally touch it, wipe it **with a cotton swab dipped in medical alcohol.**
- **Use only medical alcohol. Do not use industrial alcohol** as it may damage the print head.
- If your printer displays **error messages** frequently, clean the **label sensor regularly.**
- **The device can be safely used in tropical climates.**
- This is a Class **A** device that may cause radio interference in a home environment. In this case, the user can **take appropriate preventive measures.**