

Manual

Adjustable footrest

FeetFleet-10B

Table of contents

Specifications: 3
Set contents:..... 4
Assembly:..... 4

Specifications:

- **Warranty:** 1 year
- **Color:** Black
- **Material:** steel, sponge
- **Load: up** to 25 kg
- **Tilt angle:** +20°~-20°
- **Footrest dimensions:** 44 x 33.5 x 16 cm
- **Package dimensions:** 42x 34.5 x 17.5 cm
- **Weight:** 2 kg
- **Weight with packaging:** 2.5 kg

Set contents:

- footstool,
- cushion,
- user manual.

Assembly:

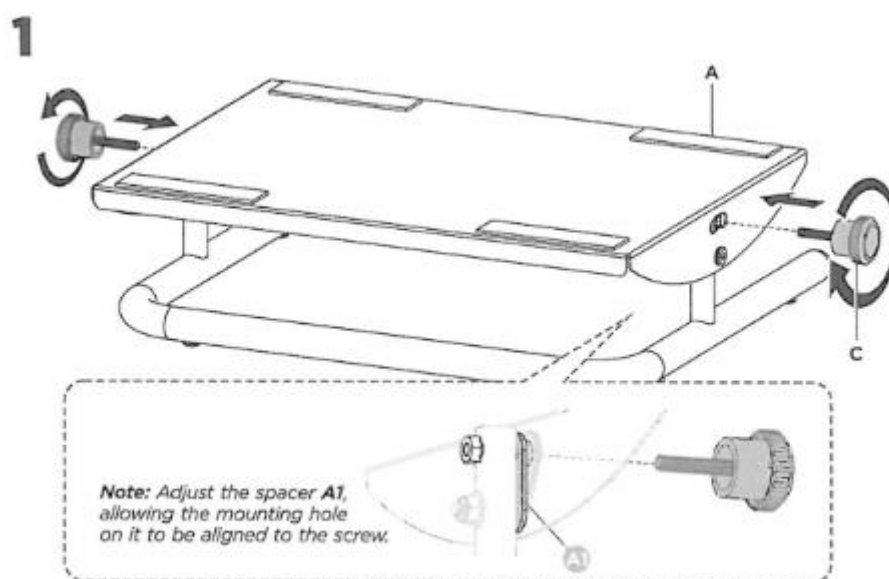
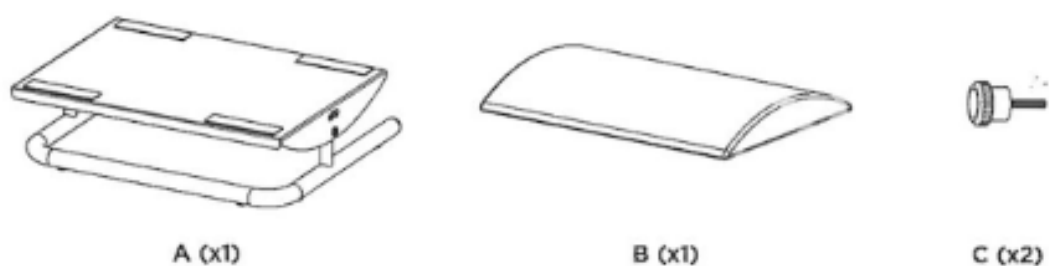

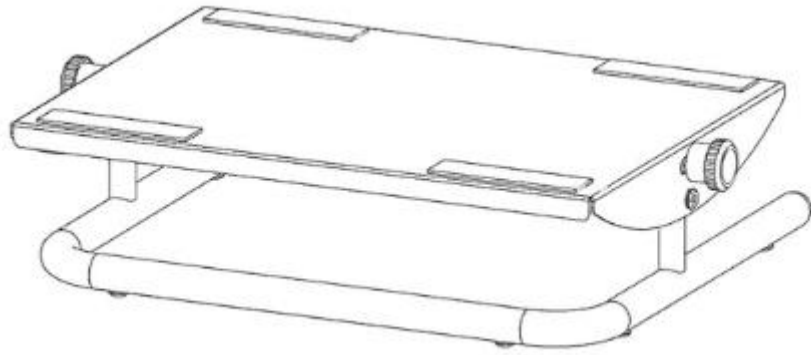

2

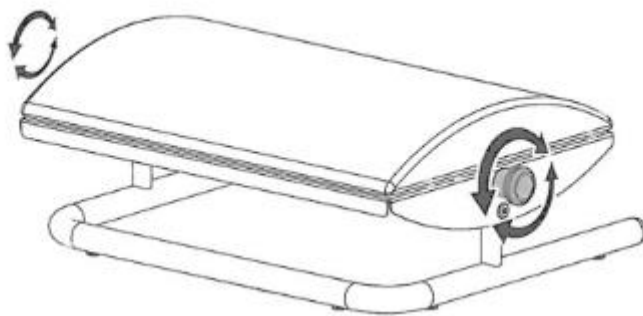
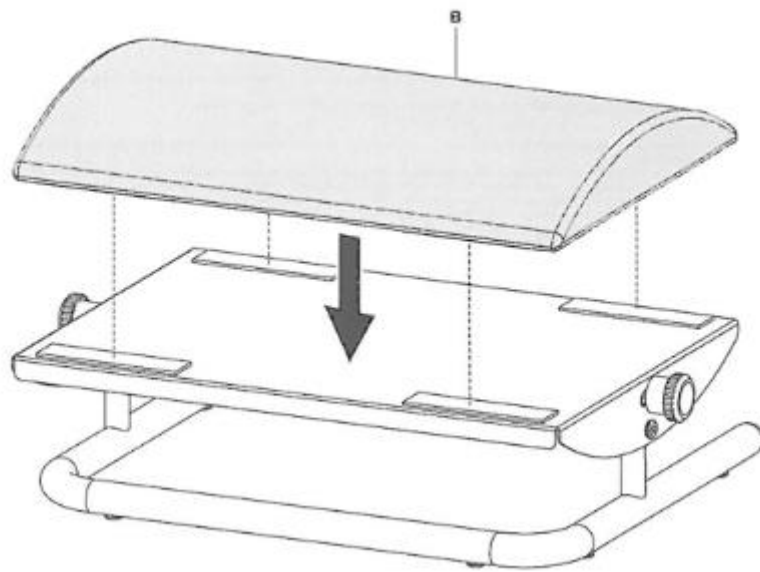

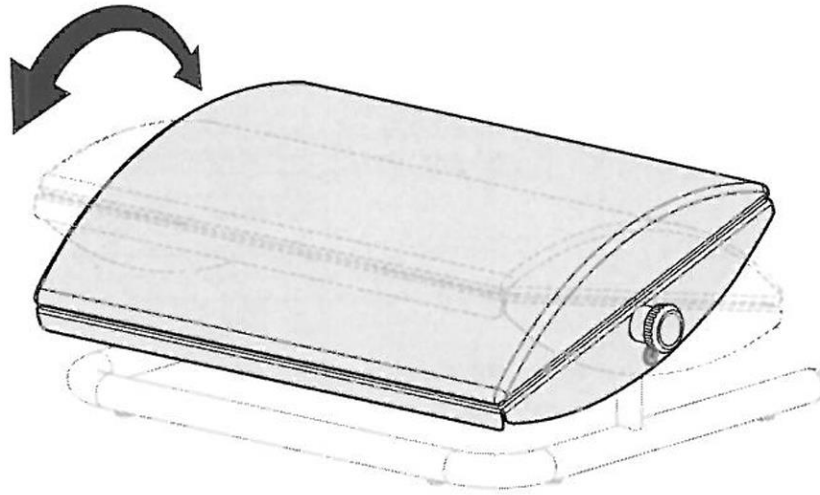

Caution: Use with products heavier than the indicated rated weight may result in instability, resulting in possible injury.

- Strict adherence to the installation instructions.
- Use protective equipment and appropriate tools.
- Use the mounting screws provided and do not overtighten them.
- This product contains small components that may pose a hazard if swallowed. Keep these items out of the reach of children.
- This product is intended for indoor use only. Use of this product outdoors may lead to its destruction.

Maintenance: Check that the product is safe to use at regular intervals (at least once every three months).