

User Manual

Time and attendance recorder

FAR01

Table of contents

- Specifications: 3
- Set contents:..... 4
- Installation instructions: 4
- Interface optimization - basic settings: 5
- Setting the department names:..... 5
- Shift work time settings:..... 6
- Adding employees:.....7
- Downloading and viewing attendance reports:..... 8
- Quick view of employee attendance records:..... 9
- Communication setting:..... 9
- Access control settings: 9

Specifications:

- **Warranty:** 1 Year
- **Model:** FAR01
- **Material:** ABS
- **Verification Type:** Fingerprint, Password, Face scan
- **Max number of employees in the base:** 3000
- **Max number of face scans in the database:** 500
- **Max. number of fingerprints in the database:** 1500
- **Max. number of entries in the database:** 500
- **Max. log capacity in the database:** 100,000
- **Number of buttons:** 16
- **Display:** 2.4 inches, 320x240
- **Supported drives:** USB FAT32
- **Connectors:** USB Type A, Rj45
- **Power supply:** 5V 1A
- **Resistance:** IP54
- **Error rate:** 1/1,000,000
- **Operating Temperature:** 0~45°C
- **Storage Temperature:** 0 ~50°C
- **Device dimensions:** 18,5 x 15,5 x 3,6 cm
- **Package dimensions:** 19,5 x 16 x 9,3 cm
- **Device weight:** 470 g
- **Weight with packaging:** 620 g

Set contents:

- FAR01 Time and Attendance Recorder
- AC adapter 230V (0.9 m)
- Mounting pins and screws
- Cable with ankle for access control connector
- Manual

Installation instructions:

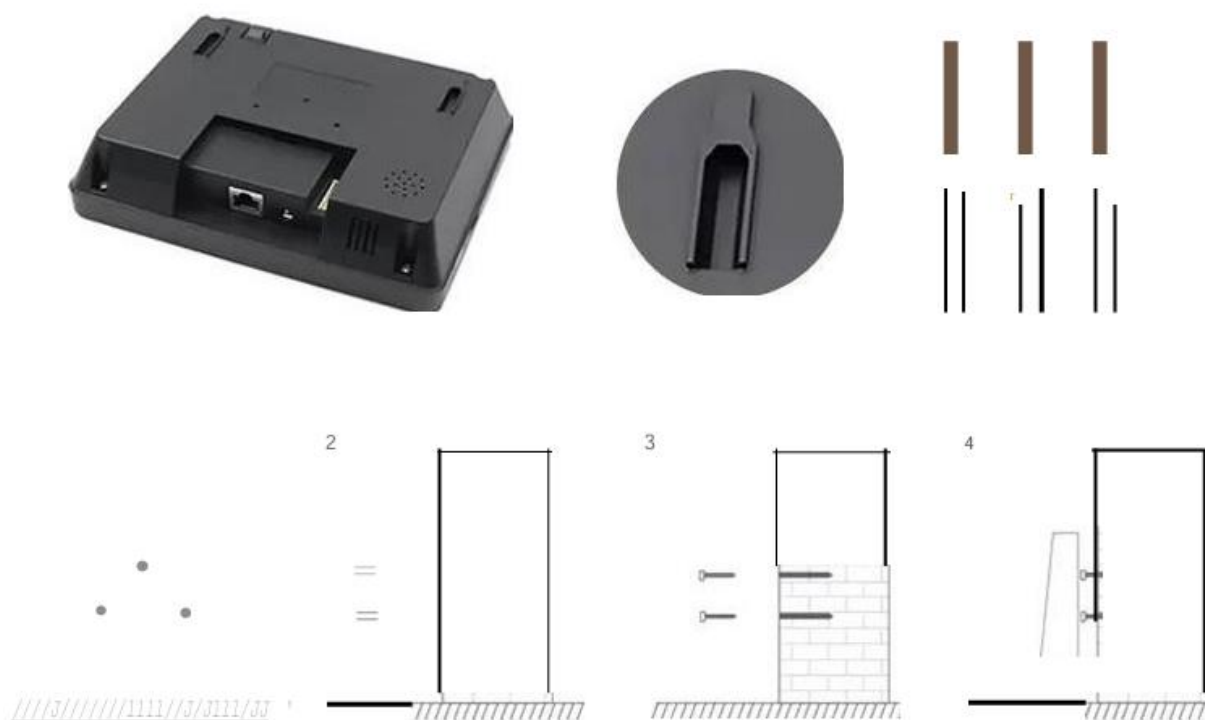

1. Make three marks on the wall where the mounting holes are drilled

2. Drill holes in the wall according to the size of the wall plugs

3. Place the wall plugs into the holes, then screw a dedicated mounting screw into each plug

4. Hang the device on the screws using the special mounting holes located on the back of the equipment case

Interface optimization – basic settings:

Buttons and Functions Description



ESC – Cancel or exit the current settings

MENU – Entry to menu management, deleting characters after entering the text field

OK – Confirm the current settings

<!> – On/Off/Switch Character Type

0-9 – Entering numbers and letters

Setting the department names:

Press [MENU] and enter the main menu. Press T to select "Attend. Rules" and press the [OK] button to enter. Press V to select "Department" and press [OK] to enter the department modification interface. Select your department with the arrows and the [OK] button to enter a new name, then press the [OK] button to save.

Shift work time settings:



	Hour	Min	Hour	Min
Time 1	08	00	12	00
Time 2	14	00	17	00
Overtime	18	00	20	00

Exit-ESC OK-OK

- 1) Press [MENU] and enter the main menu, press **..** to select **. Attend. Rules;** -> **.2. Shift"**->**Shift1'** (up to 10 shifts can be set)
- 2) Press the [OK] button to enter the hour modification option. Use the **..**, and **J** buttons to select the numbers you want to modify.

On the left are the shift start times and minutes, and on the right are the shift end hours and minutes. After changing the value in the selected field, press [OK] to confirm the changes. To exit the settings, press the [ESC] button.

EXAMPLE:

The company works in a single shift mode without overtime, morning check-in time 08:00, afternoon end time 17:00, employee drop-off twice a day.

setting for Shift1 as below

Time1 8:00-17:00 Time2 0:00-0:00 Overtime 0:00-0:00

Note: In case there are no more shift options, Shift1 is the default.

Adding employees:

Enroll

ID 000001

Name

Dept. Not Set1

Enroll

Exit-ESC OK-OK

Employee Info

1.ID	000001
2.Name	0
3.Finger	0
4.Password	0
5.Dept.	Not Set1

Exit-ESC Continue-OK

1) Press [MENU] to enter the main menu, select "Employee" and press OK. To add a new employee, select "Enroll".

2) After filling in all the data - ID (each subsequent number is assigned automatically), user name and associated department, go down to the "Enroll" key with the arrows, confirm [OK], and then exit with the [ESC] button.

To enter the employee edition, enter the "Employee" menu again and select the "Browse" option.

ID: The number assigned automatically by the system (Up to 1000 employees can be added).

Name: Ability to edit the username.

Finger: Ability to add an employee's fingerprint by reading it 2 times. To delete stored prints, enter this option and press [MENU].

Card: An RFID card can be assigned to an employee.

Password: A maximum 6-character user password can be set.

Dept.: Ability to select department affiliation.

Authority: Press [OK] to select user permissions.

Downloading and viewing attendance reports:



1) Connect an external drive or flash drive to the DVR's USB port.

2) Press [MENU] to enter the main menu, and then press v to select "Attendance".

3) Use the T key to select the reports you want to download, press the [OK] key to enter the report download interface, enter the time period you want to generate the report from, and press the [OK] key to download it.

REMARK:

FAT32 formatting is required to download reports to an external drive or flash drive. If the recording device does not recognize the disc, first format the disc to FAT32 format, and then reconnect it.

Quick view of employee attendance records:

Searching by employee ID

Menu->Log Query-> ID->Browse/Download->Enter

Search by sign-in date

Menu->LogQuery ->Date ->Browse/Download->Enter

Communication setting:

1) Press [MENU] to enter the main menu, press T to select "Setting", and then select "Communication".

2) By default, the device IP settings, gateway, subnet mask, device number, port number, communication password, and communication mode have factory settings that can be modified as needed.

3) The time and attendance logger and the time attendance software must be consistent to match the usage.

Access control settings:

1) This product supports Wiegand 26 and Wiegand 34, Input and output can be switched evenly. The Wigan input is used to read the card number seeded from other access control devices for attendance and access control.

Wigan output can choose to output card number or employee number to other access control devices, similar to connecting ID reader and password keypad.

2) A method of connecting the door lock and hardware to share power. Electricity is usually unlocked (the lock is powered separately) as shown in the figure".

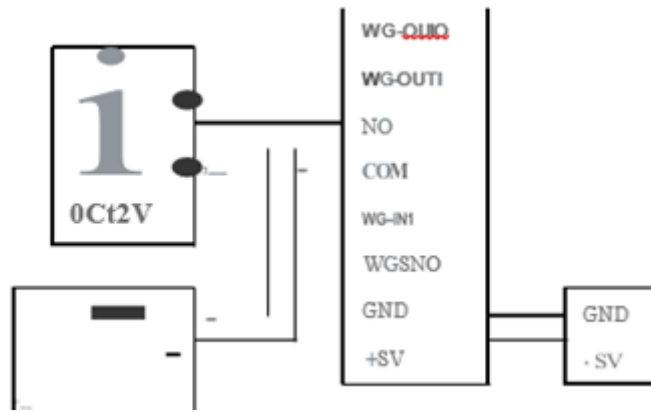

One logger can control two locks as shown below:

