

User Manual

Time and attendance recorder **CTR10**

Table of contents

- Specifications: 3
- Set contents:..... 4
- Features: 4
- Method of mounting to the wall..... 5
- Description of the access control interface 6
- Quick view of employee attendance records.....7
- Buttons and Functions Description7
- Shift time settings7
- Setting department names..... 8
- Attendance policy settings.....10
- Adding employees.....10
- Download and view attendance reports..... 11

Specifications:

- **Warranty:** 1 year
- **Model:** CTR10
- **Material:** ABS+PC
- **Frequency of cooperating key fobs and RFID cards:** 125 kHz
- **Verification Type:** Fingerprint, Password, 125kHz RFID Card/Key Fob
- **Max number of employees in the base:** 1000
- **Max number of administrators in the database:** 10
- **Max. number of fingerprints in the database:** 1000
- **Max. number of entries in the database:** 1000
- **Max. log capacity in the database:** 100,000
- **Number of buttons:** 7
- **Display:** 2.4 inch, TFT LCD
- **Supported drives:** USB FAT32
- **Connectors:** USB
- **Access Control:** Relay Output
- **Magnetic Input:** One-way Output
- **Ring/Alarm:** Local Transmission or Relay Output
- **Wiegand Input/Output:** WG26/WG34
- **Operating Voltage:** DC12V
- **Resistance:** IP54
- **Error rate:** 1/1,000,000
- **Operating Temperature:** 0~60
- **Operating Humidity:** 20~80%
- **Device dimensions:** 10.6 x 10.6 x 3.4 cm
- **Package dimensions:** 14.5 x 14 x 4.5 cm
- **Device weight:** 155 g
- **Weight with packaging:** 200 g

Set contents:

- CTR10 time and attendance recorder
- Communication tape for access control (20 cm)
- Mounting pins and screws, original instruction manual
- Polish user manual in electronic form

The set includes a communication tape with an attached 12V power supply, it is also possible to connect the recorder to a low-voltage installation of the building (such an installation is used, among others, by intercoms or alarm systems).

Features:

- **Verification Type:** Fingerprint, Password, 125kHz RFID Card/Key Fob
- **Display:** 2.4 inch, TFT LCD
- **Connectors:** USB
- **Number of buttons:** 17

Method of mounting to the wall

- 1. Remove the bottom screw with a screwdriver

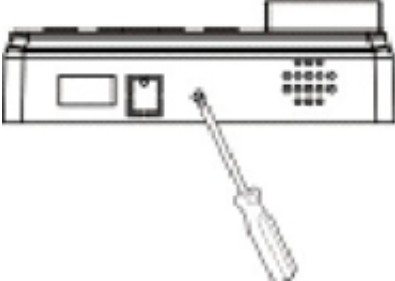

- 2. Remove the back cover from the device

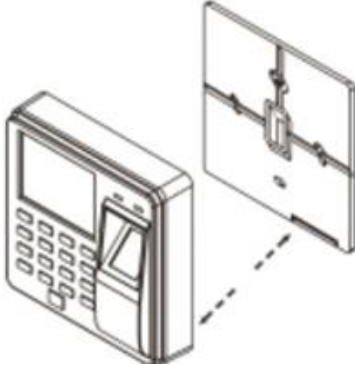

- 3. Align the holes drilled in the wall and screw the back cover to the wall with Screws

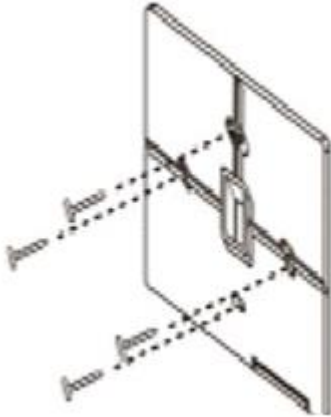

4. Install the device on the back cover

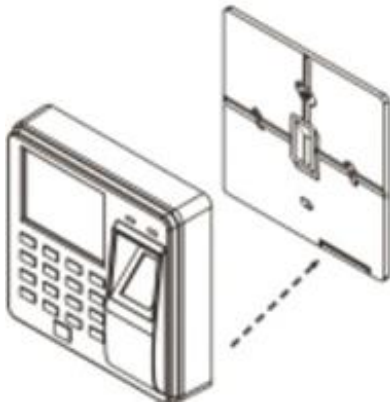

5. Lock the back cover with the bottom screw

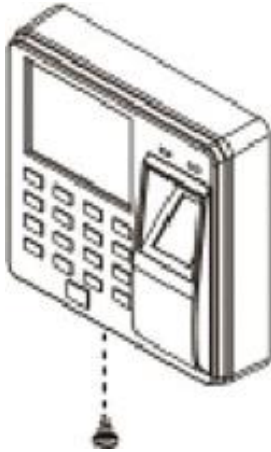

Description of the access control interface

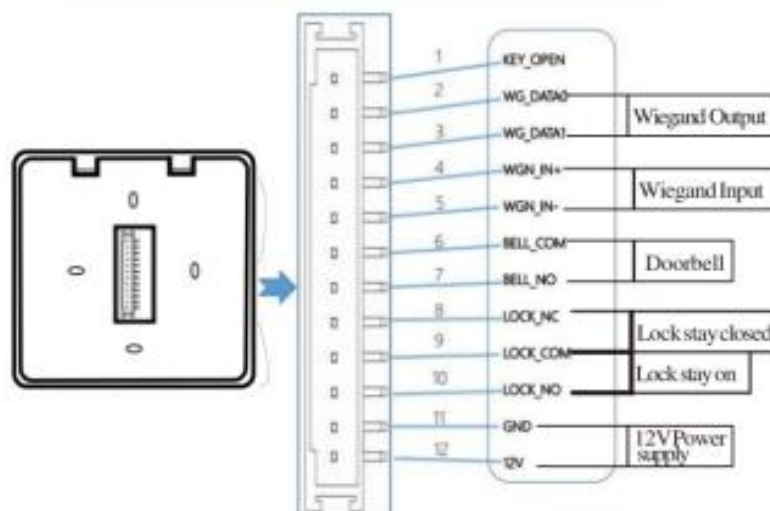

Quick view of employee attendance records

- **Searching by employee ID**

Menu - > LogQuery - > ID - > Browse/Download - > Enter

- **Search by sign-in date**

Menu -> LogQuery -> Date -> Browse/Download -> Enter

Buttons and Functions Description

ESC – Cancel or exit the current settings. Entering menu management, deleting characters after entering the text box

OK - Confirm the current settings

H - Character Type Switching

& - Move cursor up T Move cursor down

0-9 - Entering numbers and letters

Q - Ring function

Shift time settings

- 1) Press [MENU] and enter the main menu, press T to select "Attend. Rules", ->2. Shift"-> "Shift" (can be set max. Up to 10 shifts)
- 2) Press the [OK] button to enter the hour modification option. Use the 'Y' and • buttons to select the numbers you want to modify. On the left are the shift start times and minutes, and on the right are the shift end hours and minutes. After changing the value in the selected field, press [OK] to confirm the changes
To exit the settings, press [ESC].

Example:

The company works in a single shift mode without overtime, morning check-in time 08:00, afternoon end time 17:00, employee bounce

- The setting for Shift1 as below

Time1 8:00-17:00

Time2 0:00-0:00

Overtime 0:00-0:00



	Hour	Min	Hour	Min
Time 1	08	00	12	00
Time 2	14	00	17	00
Overtime	18	00	20	00

Exit-ESC OK-OK

Setting department names

1. Setting department names

Press [MENU] and enter the main menu. Press (down arrow) to select "Attend. Rules" and press the [OK] button to enter. Press V to select "Department" and press [OK] to enter the department modification interface. Select your department with the arrows and (OK) button to enter a new name, then press [OK] to save.

Department	
1.Dept. 1	Not Set1
2.Dept. 2	Not Set2
3.Dept. 3	Not Set3
4.Dept. 4	Not Set4
5.Dept. 5	Not Set5
Exit-ESC	Continue-OK

2. Set changes for a department

Press [MENU] and enter the main menu. Press (down arrow) to select "Attend. Rules" and press the [OK] button to enter. Press 'Y I' to select 'Partnment' and press [OK] to enter the department modification interface. Then select Shift1 to display the Zmlan settings interface for the department and days of the week. Numbers 1~10 indicate the Shift from 1 to 101 respectively, position 00 means holidays.

Note: When shift work is complicated or the department's schedule doesn't meet your requirements, we recommend that you download the attendance setup form to set up shifts and schedules for workers.

Dept. 1							
Week	Mon	Tue	Wed	Thu	Fri	Sat	Sun
	01	01	01	01	01	01	01
Schedu.: 1-10 Shift ,empty/0-holidays							
Exit-ESC				Ok-OK			

Attendance policy settings

Press [MENU] enter: to the main menu, press (down arrow) to select "Attend. Rules". From this level you can set m.in:

- company name
- shift work and departments arrangement
- Alarms
- Acceptable time of delays
- Acceptable early exit time



Adding employees

1. Press [MENU] to enter the main menu, select "Employee" and press OK. To add a new employee, select "ENROLL"

2. After filling in all the data - ID (each subsequent number is assigned automatically), user name and associated department, go down the arrows to the "Enroll" button, =confirm [OK], and then exit [ESC]. To enter the employee edition, enter the "Employee" menu again and select the "Browse" option. After entering, you can use the arrows and the [OK] button to select the desired employee to configure its options: ID: Number assigned automatically by the system (You can add up to 1000 employees at most) Name: Ability to edit the user name. Finger: Ability to add an employee's fingerprint by reading it 2 times. To

delete stored fingerprints, enter this option and press (MENU).

Card: An RFID card can be assigned to an employee. Password: A maximum 6-character user password can be set. Dept.: Ability to select Authority affiliation: press [OK] to select the User's Shift Time Settings permission.



Download and view attendance reports

1. Connect an external drive or flash drive to the DVR's USB port.
2. Press [MENU] to enter the main menu, then press v to select "Attendance"
3. Use the (down arrow) button to select the reports you want to download, press the [OK] key to enter the report download interface, enter: the time period to be generated from there are no more shift work options, Shift1 is the default.



REMARK:

FAT32 formatting is required to download reports to an external drive or flash drive. If the recording device does not recognize the disc, first format the disc to FAT32 format, and then reconnect it.